

BEVERAGE LINE
FOOD LINE
PLASTIC LINE
METAL LINE
WOOD LINE

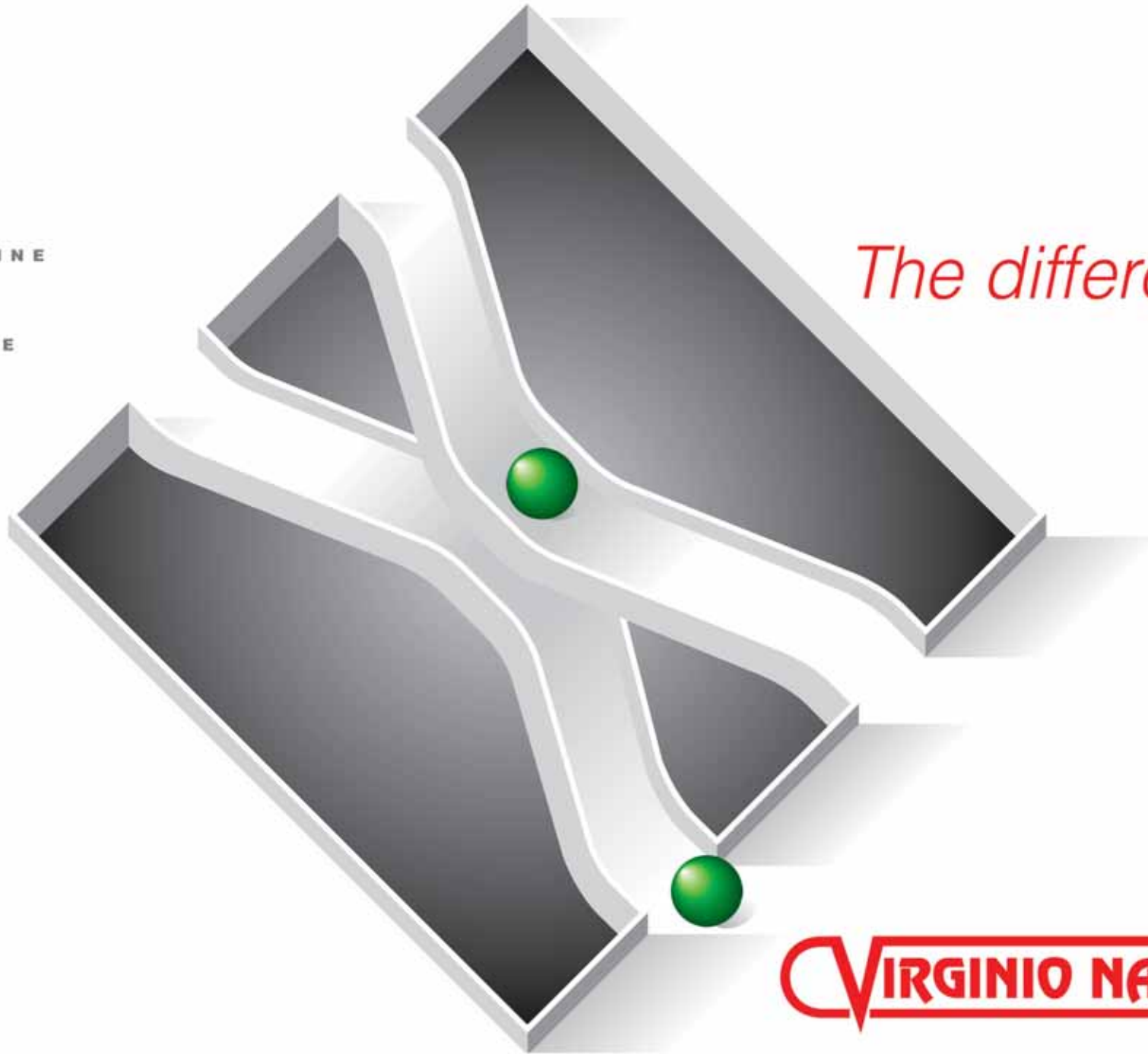

The difference

VIRGINIO NASTRI[®]

VIRGINIO NASTRI®



La Virginio Nastri nasce nel 1990 con 35 anni di esperienza nel settore delle attrezzature per materie plastiche, occupa 3500mq di cui 1000mq di carpenteria, 2000mq di montaggio e 500mq di uffici.

La produzione si suddivide in tre linee:

STANDARD LINE: produzione di nastri trasportatori standard e separatori di materozze.

CUSTOM LINE: produzione di nastri trasportatori su richiesta del cliente e impianti automatici di trasporto e gestione dei pezzi stampati.

AUTOMATION LINE: attrezzature automatiche per l'inscatolamento dei particolari stampati a bordo macchina, sia elettriche che pneumatiche.

Avremo il piacere di avere l'opportunità di discutere con voi qualsiasi progetto, vi ringraziamo per l'attenzione che ci avete concesso.



Virginio Nastri has been established since 1990 and the company's development has been based on 35 years experience of ancillary equipment for use with industrial sectors which process plastic materials.

Virginio Nastri's factory covers 3500 square metres of which 1000 sq m is for manufacture , 2000 sq m is for assembly and 500 sq m is used as offices.

Production is separated into 3 types of equipment and system principles:

STANDARD LINE: Conveyor belts and sprue separators.

CUSTOM LINE: Conveyor belts which are manufactured to customer's special requirements.
Automatic conveying systems and moulded parts control.

AUTOMATION LINE: Automatic equipment (both electric and pneumatic) for the storage and packaging of moulded parts.

Virginio Nastri is pleased to handle customer's special requirements/projects which require the design, manufacture and delivery of bespoke solutions.



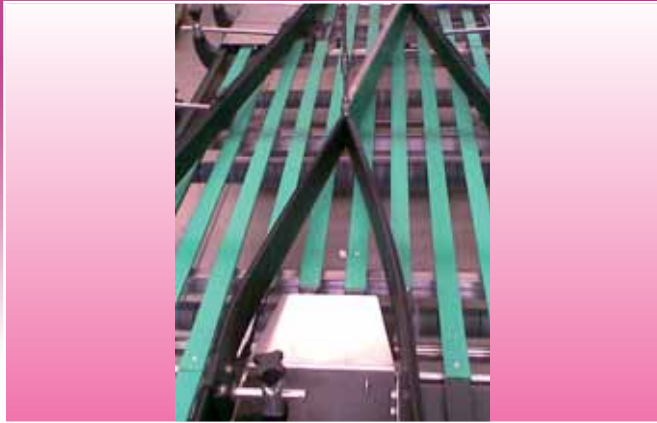



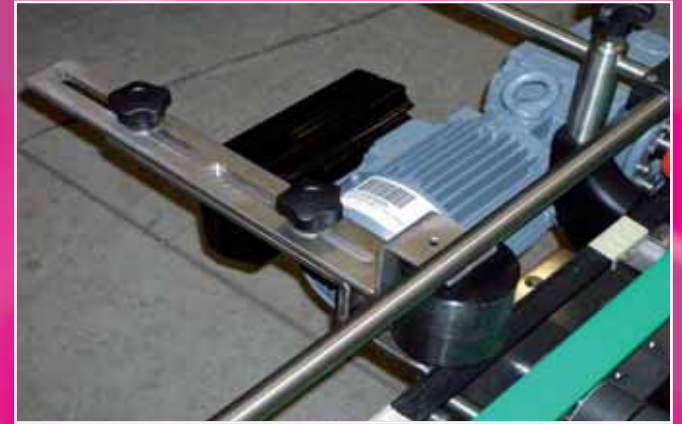

VIRGINIO NASTRI®





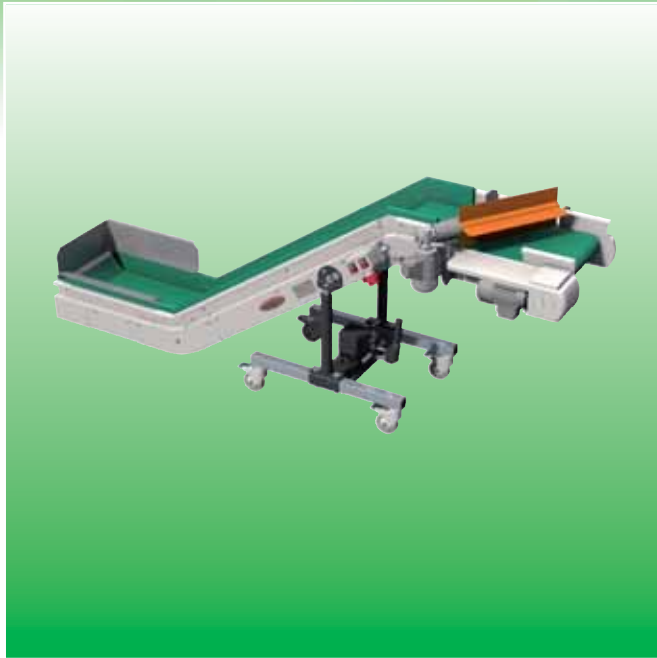
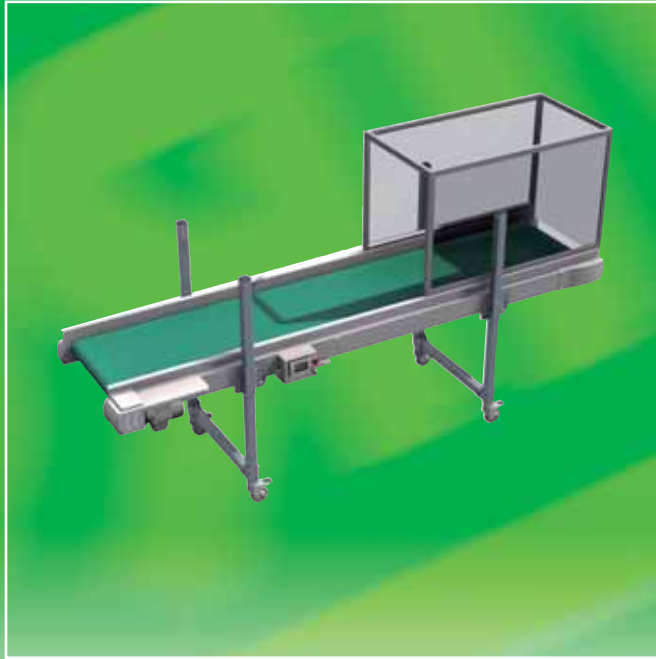

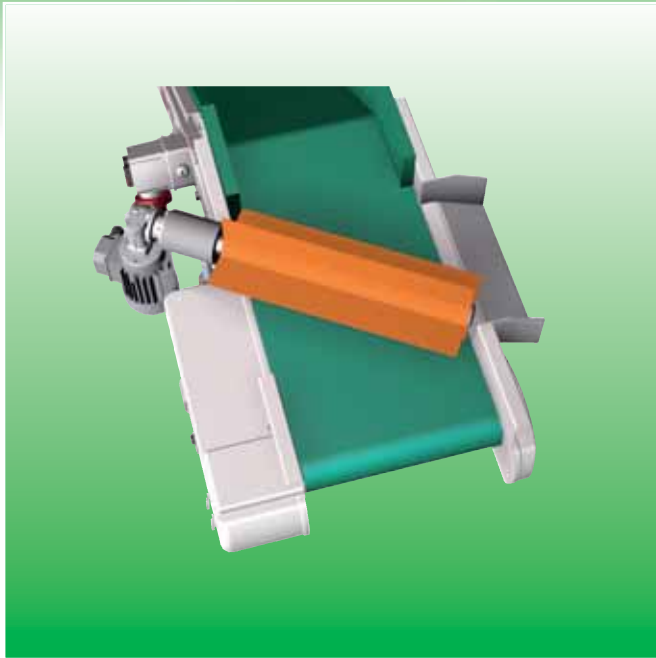

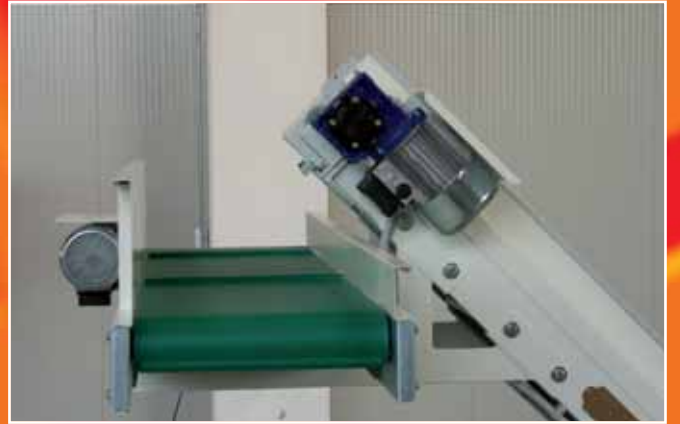

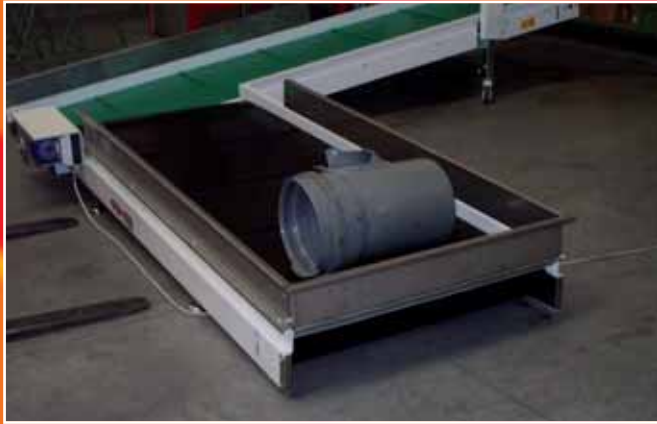

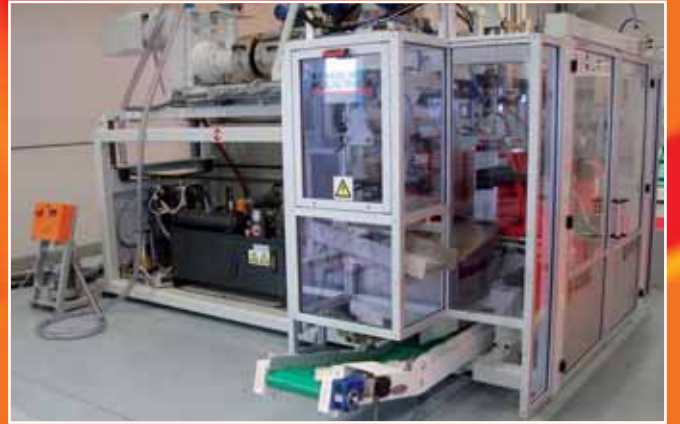



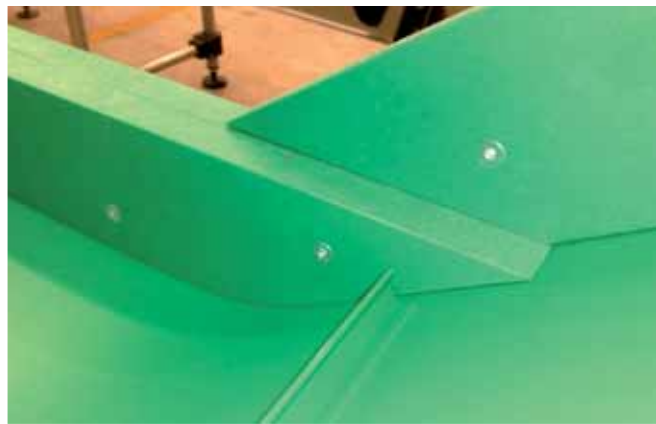





Arzignano Vicenza Italy



Ningbo - China



Limeira Sao Paolo Brasil



VIRGINIO NASTRI S.R.L.

Via 2a Strada, 161 (Z.I.) - 36071 Arzignano (VI) ITALY
Tel. +39 0444 450620 - Fax +39 0444 671840
info@virginionastri.com - www.virginionastri.com