



TrueTemp™ Econo Series Water Temperature Control Units
Reference Manual (PN: 682.91343.00) for
Complete Operation and Installation Instructions
 (Available online at www.aecinternet.com)

Quickstart Installation Checklist

(Refer to main manual for complete installation instructions).

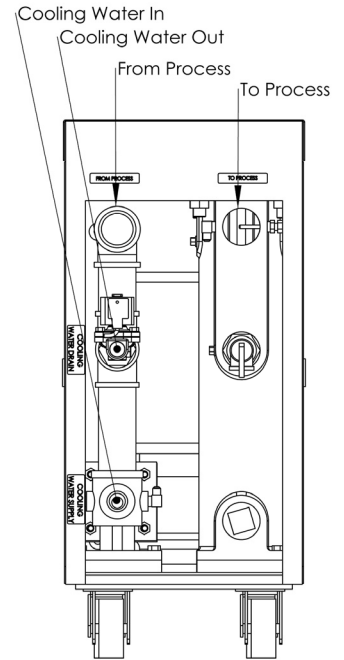

1. Connect 3-phase power based on nameplate data.
2. Install properly sized plumbing between temperature control unit and primary processing equipment (supply and return).
3. Install properly sized plumbing between temperature control unit and cooling water supply and return. Cooling water supply must be at least 16 psi (110 kPa/1.1bar) for a 250°F (121°C) configuration and 55 psi (379 kPa/3.8bar) for a 300°F (149°C) configuration.
4. Ensure proper pump rotation. (The pump should be moving clockwise while looking at the motor end).



Unit Operation

(Refer to main manual and controller manual for complete operating instructions).

Start Up

1. Push the **ON/OFF** rocker switch to the **ON (|)** to energize the unit and begin the temperature control cycle. The switch will be illuminated whenever the unit is on.
2. The unit will automatically vent for approximately one minute.
3. If needed, press and hold the vent button to purge any additional air from the process loop.
4. Set process temperature (**PV**) by pressing the  **Up Arrow** or  **Down Arrow** keys.
5. If the unit does not maintain its process value, allow your process to reach the set point temperature. Then Autotune the control by pressing the  key.

Shut Down

1. Adjust set point below 150° F (66° C). Allow unit to stabilize.
2. Push ON/OFF rocker switch to the OFF (0) position to de-energize the unit.

Standard Controller

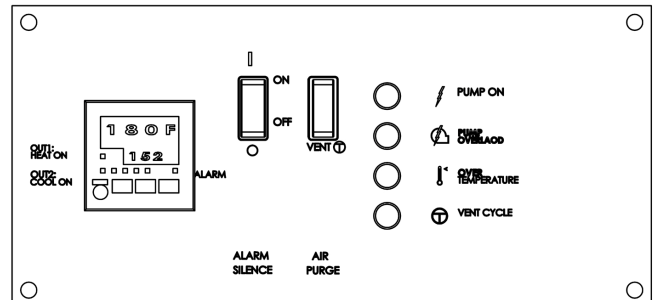



TrueTemp™ Econo Series Water Temperature Control Units
Reference Manual (PN: 682.91343.00) for
Complete Operation and Installation Instructions
(Available online at www.aecinternet.com)

Spare Parts Location
(See next page for Spare Parts List)

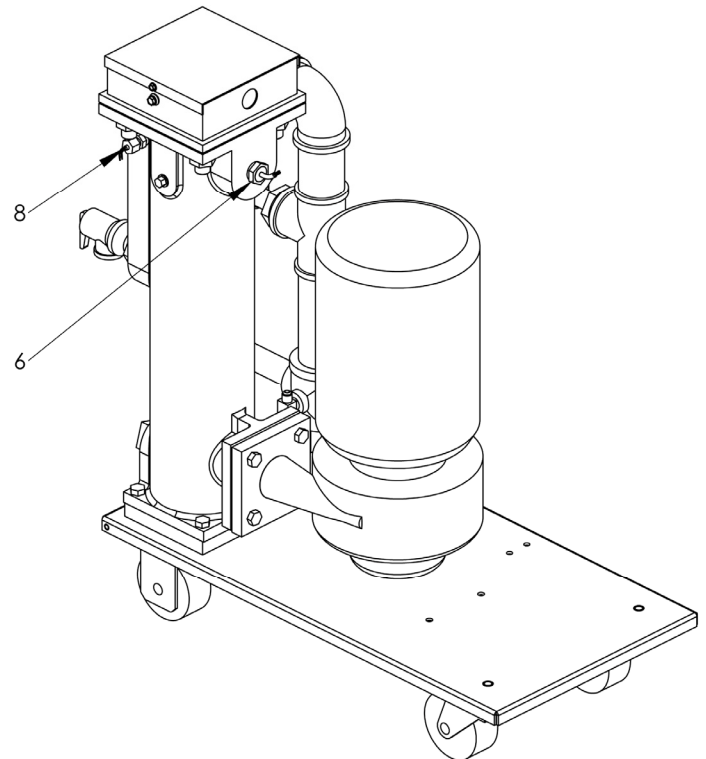
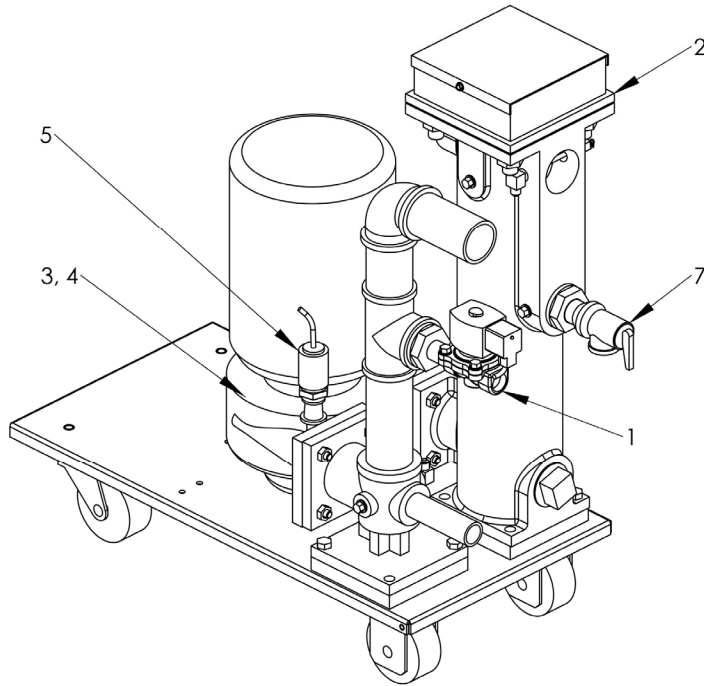



TrueTemp™ Econo Series Water Temperature Control Units
Reference Manual (PN: 682.91343.00) for
Complete Operation and Installation Instructions
 (Available online at www.aecinternet.com)

Spare Parts List
 (See previous page for Spare Parts Location)

| Cooling Valves | Standard Solenoid | | | |
|-------------------|---------------------------------|--|-------------------------------|-------------------------------|
| | 1 | ¼-inch (0.64 cm) x 5/32 orifice | 732.00024.02 | |
| | ¼ inch (0.64 cm) x 9/32 orifice | 732.00007.02 | | |
| | ½-inch (1.27 cm) | 732.00095.02 | | |
| | ¾-inch (1.91 cm) | 732.00092.02 | | |
| Immersion Heaters | 230/3/60 | | 460/3/60 | 575/3/50 |
| | 9-kW | 722.00137.02 | 722.00137.01 | 722.00137.08 |
| | 9-kW contactor (2 req'd) | 726.00268.02 | 726.00267.02 | 726.00267.02 |
| | 12-kW | 722.00137.03 | 722.00137.04 | 722.00137.22 |
| | 12-kW contactor (2 req'd) | 726.00270.02 | 726.00265.02 | 726.00265.02 |
| Motor Pumps | 230/3/60 | | 460/3/60 | 575/3/50 |
| | ¾-HP (0.56 kW) | 075.00708.00 – 250 °F (121°C) | 075.00708.00 – 250 °F (121°C) | 075.00744.00 – 250 °F (121°C) |
| | | 075.00708.01 – 300 °F (149°C) | 075.00708.01 – 300 °F (149°C) | 075.00744.01 – 300 °F (149°C) |
| | ¾-HP MCP | 726.00304.02 | 726.00303.02 | 726.00302.02 |
| | 1-HP (0.75 kW) | 075.00709.00 – 250 °F (121°C) | 075.00709.00 – 250 °F (121°C) | 075.00745.00 – 250 °F (121°C) |
| | | 075.00709.01 – 300 °F (149°C) | 075.00709.01 – 300 °F (149°C) | 075.00745.01 – 300 °F (149°C) |
| | 1-HP MCP | 726.00305.02 | 726.00303.02 | 726.00303.02 |
| | 2-HP (1.50 kW) | 075.00710.00 – 250 °F (121°C) | 075.00710.00 – 250 °F (121°C) | 075.00746.00 – 250 °F (121°C) |
| | | 075.00710.01 – 300 °F (149°C) | 075.00710.01 – 300 °F (149°C) | 075.00746.01 – 300 °F (149°C) |
| | 2-HP MCP | 726.00306.02 | 726.00304.02 | 726.00303.02 |
| | 3-HP (2.24 kW) | 075.00711.00 – 250 °F (121°C) | 075.00711.00 – 250 °F (121°C) | 075.00747.00 – 250 °F (121°C) |
| | | 075.00711.01 – 300 °F (149°C) | 075.00711.01 – 300 °F (149°C) | 075.00747.01 – 300 °F (149°C) |
| | 3-HP MCP | 726.00306.02 | 726.00305.02 | 726.00304.02 |
| | 5-HP (3.73 kW) | 075.00712.00 – 250 °F (121°C) | 075.00712.00 – 250 °F (121°C) | 075.00748.00 – 250 °F (121°C) |
| | | 075.00712.01 – 300 °F (149°C) | 075.00712.01 – 300 °F (149°C) | 075.00748.01 – 300 °F (149°C) |
| 5-HP MCP | 726.00316.02 | 726.00306.02 | 726.00305.00 | |
| 7.5-HP (5.60 kW) | 075.00713.00 – 250 °F (121°C) | 075.00713.00 – 250 °F (121°C) | 075.00749.00 – 250 °F (121°C) | |
| | 075.00713.01 – 300 °F (149°C) | 075.00713.01 – 300 °F (149°C) | 075.00749.01 – 300 °F (149°C) | |
| 7.5-HP MCP | 726.00317.02 | 726.00316.02 | 726.00306.02 | |
| Pump Seal Kits | 250 °F (121°C) (SC/C/EPDM) | | 300 °F (149°C) (SC/SC/EPDM) | |
| | ¾-HP (0.56 kW) | 162.00024.104 | 162.00024.107 | |
| | 1-HP (0.75 kW) | 162.00024.104 | 162.00024.107 | |
| | 2-HP (1.50 kW) | 162.00024.104 | 162.00024.107 | |
| | 3-HP (2.24 kW) | 162.00024.104 | 162.00024.107 | |
| | 5-HP (3.73 kW) | 162.00024.105 | 162.00024.113 | |
| | 7.5-HP (5.60 kW) | 162.00024.105 | 162.00024.113 | |
| Common Parts | 5A | 250 °F (121°C) pressure switch ** | | 692.86688.00K |
| | 5B | 300 °F (149°C) pressure switch ** | | 692.86688.01K |
| | 6A | 250 °F (121°C) safety thermostat | | 724.00665.00 |
| | 6B | 300 °F (149°C) safety thermostat | | 724.00666.00 |
| | 7 | Relief valve | | 044.00138.00 |
| | 8 | Type "K" thermocouple | | 701.00124.00 |
| | | Temperature control module (OMRON E5Cz) less outputs | | 724.00831.00 |
| | AEC Document # | 2005-spares-tcu | | |

** Reference complete manual (PN: 682.91343.00) for proper settings and installation.



TrueTemp™ Econo Series Water Temperature Control Units

Reference Manual (PN: 682.91343.00) for
Complete Operation and Installation Instructions
 (Available online at www.aecinternet.com)

Troubleshooting - Quick Guide

| Problem | Possible cause | Solution |
|--|--|---|
| Unit does not turn on | No power. | Check main disconnect, fuses, wiring, and power lead to unit. |
| | Wrong voltage supplied to unit. | Voltage must be within plus or minus 10% of nameplate rating. |
| | Defective on/off switch. | Replace. |
| | Control circuit fuse blown. | Replace. |
| | Defective control transformer. | Check transformer. |
| Unit does not run | Broken or loose wire in pump motor control circuit. | Locate and repair. |
| | Pump motor contactor holding coil is open. | Repair or replace. |
| | Low water pressure light on. | Check for at least 16 psig (110.32 kPa/1.1 bars) water pressure on WATER IN or CITY WATER MAKEUP . |
| | Water supply to unit is turned off. | Open water supply. |
| | Pump overload light on. | Reset and test each leg for balanced amp draws. |
| Temperature fluctuations/ rapid cycling from hot to cold. | Undersized connectors/ water lines. | Increase size of connectors/ water lines. |
| | Long connecting lines between unit and mold. | Move the unit closer to the mold and shorten connecting lines. |
| | Serpentine flow through mold. | Connect lines for parallel flow instead of series flow. |
| | Blocked water line in mold. | Check mold for metal chips or lime buildup. Clean mold. |
| | Quick disconnect fitting with check valve. | Remove and replace fitting or valve. |
| | Lime buildup in unit piping. | Clean or replace. |
| Unit overheats or does not cool | Drain is plugged or excessive back pressure is in drain line. | Clear drain line or eliminate back pressure condition. |
| | Faulty solenoid valve. | Test solenoid valve by pressing VENT button and listen for valve operation. Replace if faulty. |
| | Controller Cool output relay open. | Replace output relay. |
| | Solenoid valve is not operating, but COOL LED is on. | Set process temperature to minimum and check for magnetism on solenoid coil top. |
| | Solenoid coil circuit is open. | Check coil resistance. If MΩ range, replace solenoid coil. |
| | Modulating valve is not operating, but OUT2 LED is on. | Set process temperature to minimum and check for complete travel of valve. |
| | Insufficient pressure differential between cooling WATER IN and OUT lines. | Find a means to get less back pressure in the WATER OUT line. |
| | Cooling valve is undersize. | Replace cooling valve with a larger valve. |
| Unit does not heat/cannot achieve set point | Defective heater contactor. | Visually inspect coil and contacts; repair/replace defective contactors. |
| | Defective immersion heater. | Check resistance on all three (3) legs of the heater with an ohm meter. If not all equal, contact factory for replacement heater. |
| | Heater contactor is not energizing, but HEAT LED is on. | Set process temperature to maximum and check for control voltage at heater contactor. |
| | Faulty/dirty solenoid valve. | Press VENT button several times to flush the valve. |