



\$30.⁰⁰

Operation and Installation Manual

TrueTemp™ TCU Series Water Temperature Control Units

Important! Read Carefully Before Attempting to Install or Operate Equipment



Part No. 682.88106.00

Bulletin No. AE1-610.5

Write down your unit serial number(s) _____
here for future reference _____

AEC is committed
to a continuing program of product improvement.
Specifications, appearance, and dimensions described in this manual
are subject to change without notice.

© Copyright AEC, Inc. 2003		
All rights reserved.		Effective 11/29/2006
Part No. 682.88106.00	Revision E	Bulletin No. AE1.610.5

Safety Considerations

AEC, Inc. TrueTemp™ TCU Series temperature control units are designed to provide safe and reliable operation when installed and operated within design specifications, following national and local safety codes.

To avoid possible personnel injury or equipment damage when installing, operating, or maintaining this equipment, use good judgment and follow these safe practices:

- ☑ Only **PROPERLY TRAINED** personnel familiar with the information within this manual should work on this equipment.
- ☑ Follow all local **SAFETY CODES**.
- ☑ TrueTemp™ TCU cabinets and piping are hot and are a **BURN HAZARD**.
- ☑ Do not operate a TrueTemp™ TCU system without all outer panels installed. Pressurized hot water leaks can cause serious injury.
- ☑ Wear **SAFETY GLASSES** and **WORK GLOVES**.
- ☑ Use care when **LOADING, UNLOADING, RIGGING, or MOVING** this equipment.
- ☑ Operate this equipment within design specifications.
- ☑ **OPEN, TAG, and LOCK ALL DISCONNECTS** before working on equipment. AEC, Inc. recommends following OSHA Lock-Out/Tag-Out Standard 29 CFR 1910.147.
- ☑ Make sure the unit is properly **GROUNDED** before switching power on.
- ☑ When welding or brazing in or around this equipment, be sure **VENTILATION** is **ADEQUATE**. **PROTECT** adjacent materials from flame or sparks by shielding with sheet metal. An approved **FIRE EXTINGUISHER** should be close at hand and ready for use if needed.
- ☑ Do not jump or bypass any electrical safety control.
- ☑ Do not restore power until all tools, test equipment, etc. have been removed and the panels replaced.

Table of Contents

1	General Information	7
1-1	Introduction	7
1-2	Necessary Documents	8
1-3	Models Covered	8
1-4	Standard TCU Series Features	8
1-5	Available Options	9
2	Shipping Information	13
2-1	Unpacking and Inspection	13
2-2	In the Event of Shipping Damages	13
2-3	If the Shipment is Not Complete	14
2-4	If the Shipment is Not Correct	14
2-5	Returns	14
2-6	Uncrating Your New TrueTemp™ TCU System	15
3	Installation	17
3-1	Installation Location Considerations	17
3-2	Process Approach Temperature Considerations	17
3-3	External Piping Sizing Considerations	17
3-4	Piping Considerations for Permanent Installations	18
3-5	Piping Considerations for High Mobility Installations	19
3-6	Process Water Considerations	19
3-7	Making Process Water Connections	20
3-8	Making Cooling Water Connections	21
3-9	Making System Purge Connections	22
3-10	Making Electrical Connections	24
4	Identifying Controls and Features	27
4-1	Identifying Mechanical Controls and Features	27
4-2	The Microprocessor Controller	31
4-3	Controller Display	31
4-4	Using Controller Keys	32
4-5	Identifying Graphic Panel Indicators	34
4-6	Using Graphic Panel Buttons	36
4-7	Alarms	37
4-8	Controller Internal Switches	37
4-9	Controller Factory Setup	37
4-10	Auto-Tuning the Controller	37
4-11	Changing from Fahrenheit to Celsius	38
4-12	Operating the Unit with the Controller	38
4-13	Selecting Half- or Full-Heat Operation	39
4-14	Communications	40

Table of Contents

- 5 Startup and Operation..... 41**
 - 5-1 Introduction 41
 - 5-2 Startup Checklist 41
 - 5-3 Starting the Temperature Control Unit 42
 - 5-4 Operating the Unit with the Controller 43
 - 5-5 Sequence of Operation 43
 - 5-6 Checking Motor Rotation Direction..... 44
 - 5-7 Shutting Down the Temperature Control Unit 45

- 6 Unit Maintenance..... 47**
 - 6-1 Preventive Maintenance..... 47
 - 6-2 Corrective Maintenance 48
 - 6-3 Restoring the Controller to Factory Setup 50
 - 6-4 Electrical Connections..... 58
 - 6-5 Safety Devices 58
 - 6-6 Cleaning and Storage 61

- 7 Troubleshooting 62**

- I Index 66**

Charts and Figures

1	<i>Typical TrueTemp™ TCU Series Water Temperature Control Unit and Specifications</i>	11
2	<i>Typical TrueTemp™ TCU Upright Series Water Temperature Control Unit and Specifications</i>	12
3	<i>Typical Piping Schematic</i>	22
4	<i>Pump Curves; 60 Hz and 50 Hz</i>	23
5	<i>Pressure Drops</i>	23
6	<i>Typical Electrical Wiring Schematic</i>	26
7	<i>Typical E5CK Microprocessor Controller</i>	31
8	<i>Typical Graphic and Button Panels; Optional Digital Flow Meter</i>	34
9	<i>Display Readout for Mode Settings</i>	52
10	<i>Setting List for Process Temperature Controller</i>	55-57
11	<i>Process Temperature Control Error Messages Table</i>	58
12	<i>Pressure Switch; Side View and Top View</i>	60

1-1 Introduction

AEC TrueTemp™ TCU Series water temperature control units are reliable, accurate, and easy-to-use process temperature control units. They are self-contained, portable, and shipped ready to use.

The TrueTemp™ TCU Series water temperature control unit is designed to circulate water through your process and to precisely, automatically, and reliably maintain it at a specified temperature. Standard unit operating range is from 0°F (-17°C) to 250°F (121°C), or up to 300°F (149°C) as an option. The unit is suited for use with city water, water from portable or central chillers or towers, or well water.

These units are designed for rapid recirculation of a relatively small amount of water to provide close and uniform temperature relation between delivery and return lines. This performance, of course, depends on the configuration of your process and any restrictions within the mold. The recirculation, combined with the large immersion heater and cooling capability, gives fast and accurate response to bring the water up to temperature or to changes in the settings when needed.

The TCU water temperature control unit is a self-contained system consisting of a centrifugal pump, electric immersion heater, cool/vent solenoid valve, and electrical control, including a PID microprocessor controller and thermocouple. It is designed for use in process temperature control applications using water or a water/glycol mix. Any other use or fluid is **prohibited**.

Some standard safety devices include a mechanical overtemperature safety thermostat, a pressure relief valve, motor overload protection, a low pressure cutout switch, branch fusing, and non-fused lockable rotary disconnect.

A properly installed, operated, and maintained TrueTemp™ TCU system provides years of reliable operation. Please read and follow the instructions in this manual to get the most satisfaction from your TrueTemp™ TCU system.

1-2 Necessary Documents

The following documents are necessary for the operation, installation, and maintenance of AEC TrueTemp™ TCU water temperature control units. Additional copies are available from AEC, Inc.

Familiarize the appropriate personnel with these documents:

- This manual.
- The controller operation manual.
- The electrical schematic and connection diagram placed inside the control enclosure.
- The operation and installation manuals for accessories and options selected by the customer.
- The Customer Parts List included in the information packet.

1-3 Models Covered

This manual provides operation, installation, and maintenance instructions for the TrueTemp™ TCU water temperature control unit.

Model numbers are listed on the serial tag. A model number followed by **Q** indicates a specially constructed unit, and not all information in this manual may apply. Make sure that you know the model number, serial number, and operating voltage of your temperature control unit if you contact AEC, Inc.

1-4 Standard TCU Series Features

- Compact, rugged cabinet with easy-access side panels
- Cast-and-flange design to reduce connection points
- Half- and full-heat capability
- Over Current Protection for motor and transformer
- Dual stage Incoloy™ immersion heater with IEC contactors
- NEMA 12 electrical enclosure

- Forward-facing liquid-filled To and From Process pressure gauges
- Independent high temperature safety thermostat
- Non-fused lockable rotary disconnect
- Off-the-shelf microprocessor-based PID temperature controller with Process and Set Point LED readouts
- ¼" cooling solenoid valve on ¾ to 3 hp (0.56 to 2.24 kW) models; ½" slow-close cooling solenoid valve on 5 & 7½ hp (3.73 & 5.60 kW) models
- Graphic control panel with indicator and warning status lights
- Adjustable low supply water pressure switch; factory-set at 16 psig (110 kPa/1.1 bars)
- 150 psig (1,034 kPa/10.3 bars) pressure relief valve
- Choice of 208-575 operating voltages
- ¾" water supply and drain connections; 1½" process connections
- Automatic vent sequence
- 2" (51 mm) casters
- Operating range of 0°F to 250°F (-17°C to 121°C)
- Three (3) -year parts and labor warranty at the factory; five (5) -year controller warranty, and lifetime warranty on wetted pump components and pump seal; subject to factory review
- PID Auto-tuning temperature controller

1-5 Available Options

TrueTemp™ TCU systems are available with options to tailor the unit to your requirements. Some are factory installed; some can be retro-fitted in the field. Consult AEC, Inc. sales for more information. Available TrueTemp™ TCU options include:

- Digital flow meter with:
 - Up to 30 gpm (114 lpm) flow indicator
 - or -
 - 30 to 60 gpm (114 to 227 lpm) flow indicator

- or -

- Greater than 60 gpm (> 227 lpm) flow indicator
- 1/16, 1/8, 1/4 DIN PID Temperature controller with:
 - 4-20 mA current control output
 - Retransmission and Remote set point; 4-20 mA, 0-10 V
 - RS-232 or RS-485 communications (modbus, SPI, Ethernet)
 - Remote sensor; 10 ft. (3 m)
- Remote controller enclosure
- Heaters available in 12 kW, 18 kW, and 24 kW; 18 kW and 24 kW heaters available on 5 hp and 7½ hp (3.73 kW, 5.60 kW) direct-injection models only
- Closed-loop heat exchangers available in 3.7 sq. ft. and 7.4 sq. ft. (0.135 sq. m and 0.271 sq. m)
- Quick Cool function
- Auto system water purge (mold purge)
- Y-strainer
- Hammer arrestor (water hammer shock stop)
- Remote start/stop control
- Rubber feet; available in lieu of casters
- Non-ferrous brass construction
- Slow-close cooling solenoid valves available in ½" x ⅞" (C_v = 3.5) and ¾" x ¾" (C_v = 5.5)
- Modulating valves available in ½" (C_v = 0.4, 1.3, 2.2, or 4.4), ¾" (C_v = 5.5 or 7.5), 1" (C_v = 11), and 1¼" (C_v = 16)
- Two-zone stack rack with casters; common wiring and piping available
- 300°F (149°C) operation; includes silicon carbide seal
- Audible and visual general fault alarm
- Electrical operation available in 208, 460, and 575 volts, 60 Hz; 200, 380, and 415 volts, 50 Hz
- UL/cUL-listed electrical subpanel, CE Compliance, EMC low voltage directive

Figure 1
 Typical TrueTemp™ TCU Series Water Temperature Control Unit and Specifications

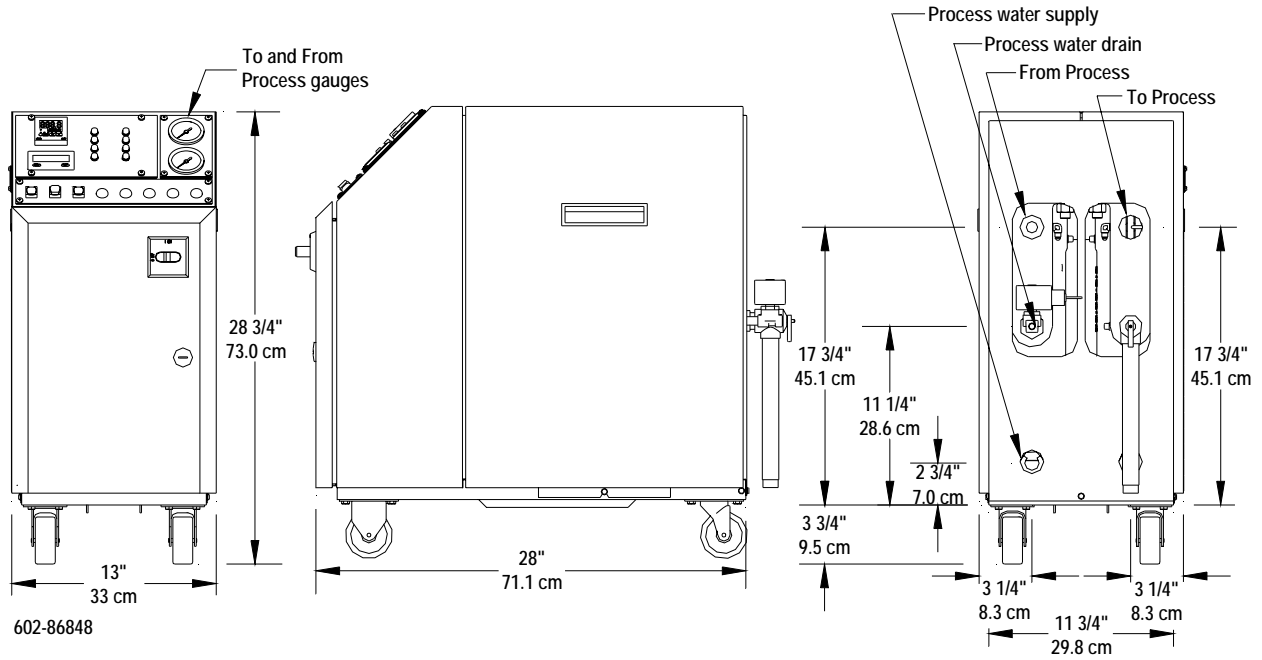

Model number	Pump						Dimensions						Shipping weight	
	hp	kW	gpm	lpm	psig	kPa	H		W		D		lbs.	Kg
							in.	cm	in.	cm	in.	cm		
TCU075	3/4	0.56	30	113.6	25	172.4	28 3/4"	73.0	13"	33	28"	71.1	210	96
TCU100	1	0.75	35	132.5	30	206.9	28 3/4"	73.0	13"	33	28"	71.1	210	96
TCU200	2	1.50	50	189.3	30	206.9	28 3/4"	73.0	13"	33	28"	71.1	210	96
TCU300	3	2.24	60	227.1	35	241.3	28 3/4"	73.0	13"	33	28"	71.1	210	96
TCU500	5	3.73	90	340.7	50	344.8	28 3/4"	73.0	13"	33	28"	71.1	240	109
TCU750	7 1/2	5.60	120	454.2	50	344.8	28 3/4"	73.0	13"	33	28"	71.1	240	109

Figure 2
 Typical TrueTemp™ TCU Upright Series Water Temperature Control Unit
 and Specifications

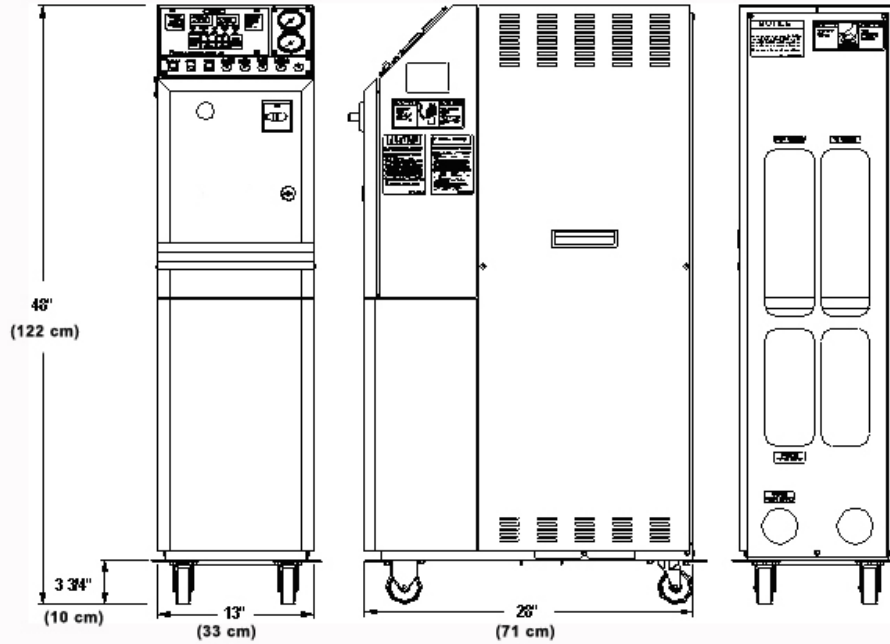

Model number	Pump						Dimensions						Shipping weight	
	hp	kW	gpm	lpm	psig	kPa	H		W		D		lbs.	Kg
460 / 230							in.	cm	in.	cm	in.	cm		
TCU075U	¾	0.56	30	113.6	25	172.4	49 7/8"	127	13"	33	28"	71.1	240	109
TCU100U	1	0.75	35	132.5	30	206.9								
TCU200U	2	1.50	50	189.3	30	206.9								
TCU300U	3	2.24	60	227.1	35	241.3								
TCU500U	5	3.73	75	283.9	50	344.8							270	123
TCU750U	7½	5.60	90	340.7	50	344.8								
TCU1000U	10	7.46	120	454.2	55	379.2								

Additional Specifications

Model		Full-load amps at 460 volts ①				Pressure drop flow and loss			
hp	kW	9 kW htr	12 kW htr	18 kW htr	24 kW htr	flow gpm	flow lpm	loss psi	loss kPa
0.75 hp	0.56 kW	12.7 amps	16.5 amps	24.0 amps	31.6 amps	30.0 gpm	113.6 lpm	0.0 psi	0.0 kPa
1.00 hp	0.75 kW	13.1 amps	16.9 amps	24.4 amps	32.0 amps	35.0 gpm	132.5 lpm	1.0 psi	6.9 kPa
2.00 hp	1.50 kW	14.7 amps	18.5 amps	26.0 amps	33.6 amps	50.0 gpm	189.3 lpm	1.5 psi	10.3 kPa
3.00 hp	2.24 kW	16.1 amps	19.9 amps	27.4 amps	35.0 amps	60.0 gpm	227.1 lpm	2.0 psi	13.8 kPa
5.00 hp	3.73 kW	18.9 amps	22.7 amps	30.2 amps	37.8 amps	75.0 gpm	283.9 lpm	2.5 psi	17.2 kPa
7.50 hp	5.60 kW	22.3 amps	26.1 amps	33.6 amps	41.2 amps	90.0 gpm	340.7 lpm	5.0 psi	34.4 kPa
10.00 hp	7.46 kW	25.0 amps	28.5 amps	36.0 amps	43.0 amps	120.0 gpm	454.2 lpm	5.0 psi	34.4 kPa

① To calculate full load amps at 230 volts, multiply by 2.0.

2

Shipping Information

2-1 Unpacking and Inspection

You should inspect your AEC TrueTemp™ TCU Series temperature control unit for possible shipping damage. If the container and packing materials are in re-usable condition, save them for reshipment if necessary.

Thoroughly check the equipment for any damage that might have occurred in transit, such as broken or loose wiring and components, loose hardware and mounting screws, etc. In case of breakage, damage, shortage, or incorrect shipment, refer to the following sections.

2-2 In the Event of Shipping Damages

Important!

According to the contract terms and conditions of the Carrier, the responsibility of the Shipper ends at the time and place of shipment.

- ☑ Notify the transportation company's local agent if you discover damage.
- ☑ Hold the damaged goods and packing material for the examining agent's inspection. **Do not return any goods to AEC, Inc. before the transportation company inspection and authorization.**
- ☑ File a claim against the transportation company. Substantiate the claim by referring to the agent's report. A certified copy of our invoice is available upon request. The original Bill of Lading is attached to our original invoice. If the shipment was prepaid, contact AEC at (847) 273-7700 for a receipted transportation bill.
- ☑ **Advise AEC, Inc. regarding your request for replacement and to obtain an RMA (return material authorization) number.**

2-3 If the Shipment is Not Complete

Check the packing list. The apparent shortage may be intentional. Back-ordered items are noted on the packing list. You should have:

- AEC TrueTemp™ TCU Series water temperature control unit
- Bill of lading
- Packing list
- Operating and Installation packet
- Electrical schematic and panel layout drawings
- Component instruction manuals

Re-inspect the container and packing material to see if you missed any smaller items during unpacking. Determine that the item was not inadvertently taken from the area before you checked in the shipment. Notify AEC, Inc. immediately of the shortage.

2-4 If the Shipment is Not Correct

If the shipment is not what you ordered, **contact AEC, Inc. immediately**. Include the order number and item. *Hold the items until you receive shipping instructions.*

2-5 Returns

Important!

**Do not return any damaged or incorrect items
until you receive shipping instructions from AEC, Inc.**

2-6 Uncrating Your New TrueTemp™ TCU System

- ☑ TrueTemp™ TCU Series water temperature control units are shipped fastened to a skid and covered with a cardboard box.
- ☑ Carefully remove the staples on the bottom of the box, lift off the box, and remove the bolts holding the unit to the skid.

Caution!

Be careful when cutting straps.

Straps may spring back and cause injury!

- ☑ From the side, slip two lifting straps between the skid and temperature control unit. Spread the straps from the center line so it is balanced.
- ☑ Loop the straps over a fork truck fork. Lift slowly and only high enough to clear the skid. Use a pry bar if necessary to remove the skid from the unit.
- ☑ Carefully slide the skid from beneath the unit and lower the unit. Lower slowly. The unit should land on its casters and can be rolled into position.
- ☑ Retain the crating in case reshipment is necessary due to hidden shipping damage.

- Notes -

3-1 Installation Location Considerations

TrueTemp™ TCU systems are portable and can be installed almost anywhere. As with all equipment installations, follow all applicable codes and regulations.

- ☑ The recommended ambient temperature range for TrueTemp™ TCU installations is from +14°F (-10°C) to a maximum operating ambient temperature of 131°F (55°C). Recommended ambient storage temperature range is from -13°F to 149°F (-25°C to 65°C). If storing the unit below freezing temperatures, make sure the unit has an antifreeze mixture circulated inside.
- ☑ Provide a minimum of twelve inches (12" or about 30 cm) clearance on all side of the cabinet to allow circulation of cooling air.
- ☑ Locate the unit as close to the process as is practical.

3-2 Process Approach Temperature Considerations

If the differential (Δ) between **COOLING WATER IN** and **TO PROCESS** temperatures is less than 10°F (7°C), consult our Sales Department for advice on how to control low approach applications.

3-3 External Piping Sizing Considerations

- ☑ All external hose and piping should be adequately sized to assure minimum external pressure drop.
- ☑ Low external piping pressure drop is needed for best operation.

Note: Use a backup wrench to support TrueTemp™ TCU system piping when making process piping connections.

! CAUTION

All external valves, fittings, and hoses must be rated at a minimum of 150 psig and 250°F (1,034.25 kPa/10.34 bars and 121°C).

The exception is when the temperature control unit is optionally rated for 300°F (149°C) operation; external valves fittings and hoses must then be rated at a minimum of 150 psig and 300°F (1,034.25 kPa/10.34 bars and 121°C).

3-4 Piping Considerations for Permanent Installations

AEC, Inc. recommends an optional (or customer-installed) strainer on the **COOLING WATER IN** inlet.

The unit must have at least 16 psig (110.32 kPa/1.1 bars) water supply pressure to prevent pump cavitation that can be caused by the water “flashing” to steam. To avoid damage to the pump or other components, make sure that maximum supply pressure does not exceed 55 psig (379.2 kPa/3.79 bars).

Keep restrictions to a minimum by using proper inlet pipe sizing. If the water supply piping is larger than ¾”, reduce the size at the unit. The table below contains the pipe sizes that are used in the unit.

Pipe sizes for ¾ hp to 10 hp (0.56 kW to 7.46 kW) units	
Location	Size in inches NPT
Process delivery	1½”
Process return	1½”
Water supply	¾”
Drain	- depends on solenoid used -

Common black pipe is recommended for permanent installations. TrueTemp™ TCU water circuit piping is primarily ferrous (iron) and reacts electro-chemically with non-ferrous metallic materials such as copper. Some water contains dissolved minerals that greatly accelerates the reaction between dissimilar metals. Ferrous piping is recommended to minimize galvanic action. If piping must be copper, use dielectric unions at the unit.

3-5 Piping Considerations for High Mobility Installations

Mobile TrueTemp™ TCU Series systems must use high quality hose rated for **at least** 150 psig and 250°F (1,034.25 kPa/10.34 bars and 121°C). Special 300°F (149°C) high temperature TrueTemp™ TCU Series systems must use hosing rated at 150 psig and 300°F (1,034.25 kPa/10.34 bars and 149°C) or greater.

Quick disconnects may be used for mobility, although **they cause a drop in pressure**. If used, they must be sized carefully to minimize pressure drop. Don't use quick disconnects with check valves *unless absolutely necessary*.

! CAUTION

Non-relieving quick connect fittings or check valves on the water supply must have a pressure relief piped to the drain.

Failure to do so could result in a dangerous over-pressure condition!

3-6 Process Water Considerations

Raw Water

Water treatment is vital in any piping system. In some cases, raw water may be used in the system without problems; in other cases, it can result in large deposits of scale and corrosion.

AEC, Inc. offers a complete line of water treatment equipment. Contact your AEC, Inc. sales representative for water testing and treatment options.

Distilled Water

Non-ferrous (brass, copper or high-temperature plastic) piping is recommended for distilled water processes.

Deionized Water

Stainless steel (316 SS minimum) or PVC plastic components must be used with deionized water. AEC, Inc. recommends stainless steel because of the temperature constraints with plastic.

3-7 Making Process Water Connections

Closed Circuit/Direct Injection

For both types of systems, the connections are basically the same. On the back of each unit, the connections are labeled appropriately. Connect the **DELIVERY** hookup to the entrance of the process and the **RETURN** hookup to the exit of the process. Connect the **WATER SUPPLY** to your plant water supply. Connect the **DRAIN** line to an open drain, or to the return line of your central water system.

Make sure you carefully select the connecting lines and connectors between the temperature control unit and the process to suit the needs and requirements of your application.

If your unit has a maximum operating temperature of 250°F (121°C), the connecting lines and connectors should have a service rating of at least 250°F (121°C) and 150 psig (1,034.25 kPa/10.34 bars). If it has a maximum temperature of 300°F (149°C), the lines and connectors should have a service rating of at least 300°F (149°C) and 150 psig (1,034.25 kPa/10.34 bars).

TO PROCESS — 1½” NPT

This is the outlet for the tempered water leading to the process being controlled.

FROM PROCESS — 1½” NPT

Water from the process re-enters the TrueTemp™ TCU Series system to be tempered and re-circulated back into the process.

3-8 Making Cooling Water Connections

WATER IN — 3/4"

The cooling water supply inlet from a cooling tower, a chiller, or a city water supply.

! CAUTION

If a non-relieving device such as a regulator, ball valve, or check valve is installed on the WATER IN line, you **MUST** install an expansion tank of at least 1/2 gallon (about 2 liters) capacity.

Failure to do so can result in system overpressure from thermal expansion. Install the tank configured as shown below:

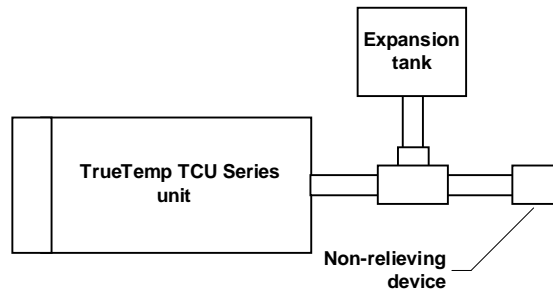

Check the expansion tank frequently to make sure it is not flooded.

Water Out

Size Depends on Solenoid Used

The cooling water return outlet leading back to the cooling tower, chiller, or drain.

Net supply pressure must be between 25 psig and 55 psig (172.38 kPa/1.72 bars and 379.21 kPa/ 3.79 bars). Net supply below 15 psig (103.43 kPa/1.03 bars) may allow water to flash to steam, cavitate the impeller, and **damage the pump**, which prevents the unit from cooling properly. Operation above 55 psig (379.21 kPa/3.79 bars) may cause premature opening of the relief valve from pump pressure and pressure surges.

PRESSURE RELIEF — 3/4"

The pressure relief valve must be piped to an open and unrestricted drain. Terminate in a manner to prevent scalding of nearby personnel in the event that the relief valve trips.

3-9 Making System Purge Connections

TrueTemp™ TCU Series systems equipped with the System Purge option have a compressed air inlet marked **MOLD PURGE**. Connect to a clean, dry 100 psig (689.50 kPa/6.90 bars) air line. Install your own shutoff valve to prevent process liquid from backing up into the plant air piping if the compressed air is turned off and the check valve fails. **Don't depend on the solenoid valve to hold water pressure in the temperature control unit.**

Figure 3
Typical Piping Schematic

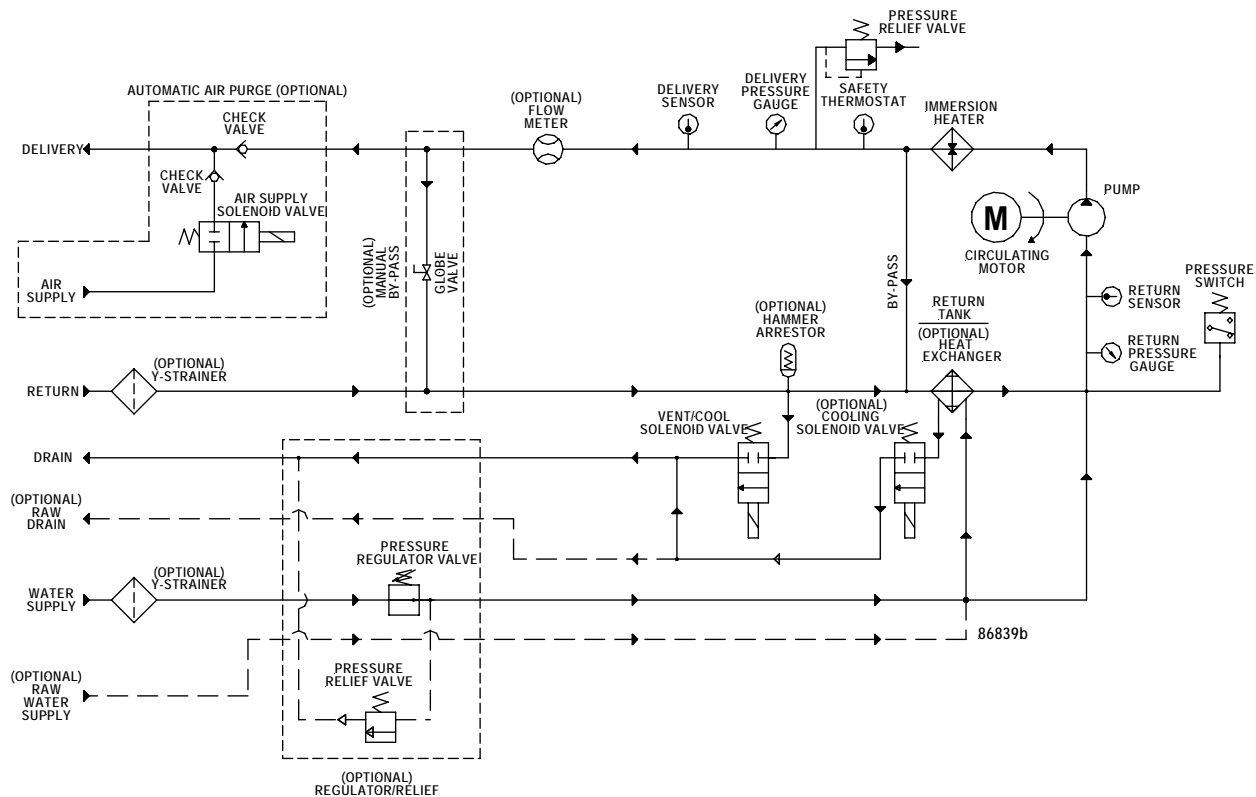
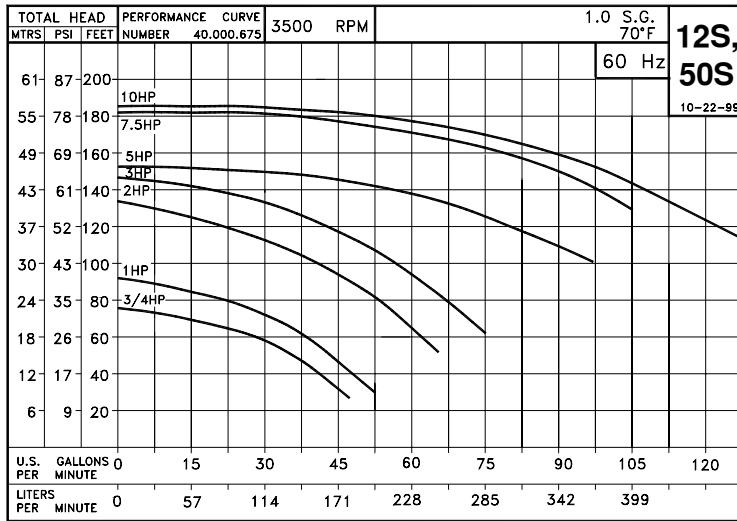

Figure 4
Pump Curves; 60 Hz



Pump Curves; 50 Hz • Consult Factory for 10 hp Curves

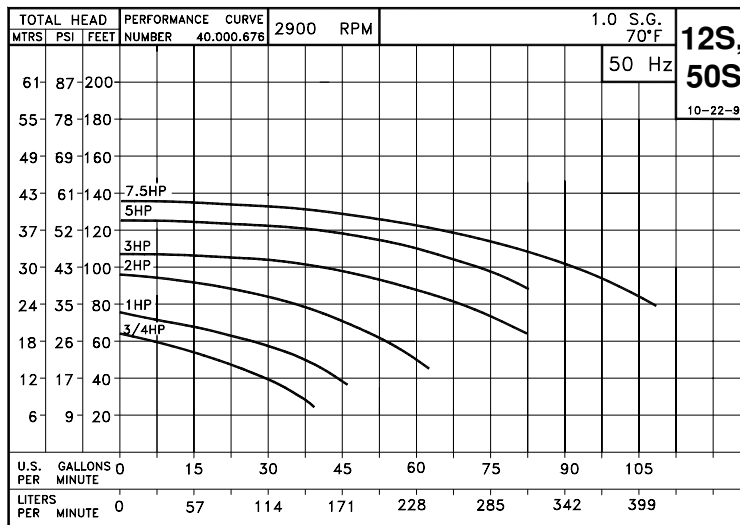

Figure 5
Pressure Drops

Model		Pressure drop flow and loss				
hp	kW	9 kW htr	flow gpm	flow lpm	loss psi	loss kPa
0.75 hp	0.56 kW	12.7 amps	30.0 gpm	113.6 lpm	0.0 psi	0.0 kPa
1.00 hp	0.75 kW	13.1 amps	35.0 gpm	132.5 lpm	1.0 psi	6.9 kPa
2.00 hp	1.50 kW	14.7 amps	50.0 gpm	189.3 lpm	1.5 psi	10.3 kPa
3.00 hp	2.24 kW	16.1 amps	60.0 gpm	227.1 lpm	2.0 psi	13.8 kPa
5.00 hp	3.73 kW	18.9 amps	75.0 gpm	283.9 lpm	2.5 psi	17.2 kPa
7.50 hp	5.60 kW	22.3 amps	90.0 gpm	340.7 lpm	5.0 psi	34.4 kPa
10.00 hp	7.46 kW	26.0 amps	120.0 gpm	454.2 lpm	5.0 psi	34.4 kPa

3-10 Making Electrical Connections

TrueTemp™ TCU Series systems are designed for three-phase voltage operation. Refer to the unit nameplate for proper voltage and amperage requirements.

Make sure you provide a correctly sized and protected supply of electrical power to the unit.

Important!

Refer to National Electric Code (NEC) Article 430-24 through 430-26 for proper feeder conductor and supply disconnect sizing.

Maintain a safe ground and disconnect the power supply before servicing the unit. A qualified electrician should make electrical connections, and disconnect and lock out electricity using OSHA 29CFR 1910.147 standards when you need a service call.

Check serial tag voltage and amperage requirements and make sure your electrical service conforms *before* making any electrical connections. Total running amps for TrueTemp™ TCU Series systems are listed on the nameplate. Customer connections can be run to the supply terminals from either side of the unit. Make sure that all three phases are wired correctly. If not wired properly, the unit will run *backwards*. **Again, check the unit nameplate for correct voltage and amperage.**

! DANGER



Improper electrical connections can damage the unit and cause serious operator injury or death!

Bring properly sized power leads and ground from a fused disconnect (installed by your electrician) to the unit. Provide external overcurrent protection to the unit, using circuit breakers or fuses. If you use fuses, make sure that they are dual-element time-delay fuses, sized according to your electrical code. Make sure that **all** electrical connections are *tight*.

Important!

- 1. Electrical connections must comply with all applicable electrical codes.**
- 2. The temperature control unit must be grounded in accordance with NEC Article 250.**
- 3. Voltage must be within plus or minus ten percent ($\pm 10\%$) of the nameplate rating.**
- 4. Make sure your installer provides external protection.**

Figure 6
Typical Electrical Wiring Schematic

**Please refer to the electrical wiring diagrams supplied
with your unit's Customer Information Packet.**

4 Identifying Controls and Features

4-1 Identifying Mechanical Controls and Features

To Process Thermocouple

A type K ungrounded thermocouple with a 304SS probe is downstream from the heater to sense process temperature.

Safety Thermostat

The safety thermostat mounted on the side of the heater tank protects against thermal runaway. The thermostat guards against the unlikely event of “runaway” heating. If overheating occurs, the safety thermostat shuts down heater outputs. The unit continues to pump water through the system to prevent heater damage. AEC recommends that you install an audible or visual alarm to the terminals provided. Factory installed alarms are available; see the electrical schematics in the installation packet for more information.

Pressure Relief Valve

If the combined pressure of the cooling supply water and pump discharge exceeds 150 psig (1,034.25 kPa/10.34 bars), the pressure relief valve opens and relieves the pressure. This is a non-adjustable ASME construction valve with a stainless steel spring.

Important!

**Route a pipe from the pressure relief valve
to a suitable drain to reduce potential scalding hazard.**

The drain line must not have any restrictions or back pressure.

Low Pressure Cutout Switch

This switch (set at 16 psig, 2 psig differential [110.3 kPa/1.10 bars with a 13.79 kPa/0.14 bars differential]) shuts down the unit if the **COOLING WATER IN** or **MAKEUP** water pressure drops below 16 psig (110.3 kPa/1.10 bars).

Pumps

Pumps range in power from $\frac{3}{4}$ hp to $7\frac{1}{2}$ hp (0.56 kW to 5.59 kW) and are equipped with 3-phase ODP motors and seal flush lines as standard.

The pump is a bronze-fitted straight centrifugal type. It features a split case design to facilitate replacement of the seal. It has a high output capacity with excellent discharge pressure helping it facilitate turbulence to maximize heat transfer, and is well suited for the conditions under which it was designed to operate.

Heaters

The specially designed 9 kW three-phase low watt density electrical immersion heater heats the water, and the controller regulates the temperature. The standard heater has an incolloy sheath for best heat transfer.

Low watt density immersion heaters at 12 kW, 18 kW (dual 9 kW heaters), or 24 kW (dual 12 kW heaters) are available options for these models, depending upon the heating needs of the process. All models are built to provide full or partial heat as required by the process and determined by the controller, providing more precise temperature control.

Solenoid Valves

TrueTemp™ TCU Series systems use rugged, industrial design solenoids with replaceable coils and/or internal components. Depending on required cooling capacity, solenoid valves are available in sizes ranging from $\frac{1}{4}$ " to $\frac{3}{4}$ "; $\frac{1}{2}$ " x $\frac{9}{16}$ " and $\frac{3}{4}$ " x $\frac{3}{4}$ " solenoid valves are slow-closing.

Motorized Modulating Valves

Optional

Optional motorized modulating valves are recommended for large cooling applications where the process temperature is very near the cooling water supply temperature. The gradual shutoff they provide also eliminates water hammer. The option includes a complete valve and motor package in place of a long-life solenoid valve.

The motorized modulating valve has infinite positioning.

Water Hammer Arrestor (Shock Stop)

Optional

Shock waves from fast-operating solenoid valves may damage some process systems. For these applications, a welded metal bellows-type shock stop with a pre-charged and sealed nitrogen blanket can be installed in the cooling piping.

Pump Starter

TrueTemp™ TCU Series high quality IEC-rated pump motor starters are industrial grade motor controls with overload and overcurrent protection with manual reset.

Transformer

High quality industrial design transformers are specified to suit incoming voltage on the application and provide 115 VAC control voltage. The transformer is protected by primary fusing with secondary grounding.

Heater Contactor

Your TCU unit uses high-quality IEC-rated industrial-grade electromechanical contactors for heater controls.

Cooling

The controller automatically regulates cooling by opening and closing the solenoid valve or modulating valve. For direct injection, the unit cools by removing the required amount of warm water from the system. This process permits an equal amount of cool plant water to enter the system well ahead of the pump, allowing it to blend with the system water. The water supply temperature governs the minimum operating temperature of the unit.

For closed circuit operation, the unit cools by automatically releasing cooling water through the tubes of the specially designed shell and tube heat exchanger in each zone. The process fluid, such as water, glycol, or other similar fluid, is circulated through the shell of the heat exchanger.

Note: The plant water supply temperature governs the minimum operating temperature of the unit.

Electricals

The pump motor and the immersion heater operate on three-phase 50/60 cycle nominal voltages with the control circuit operating at 115V single phase. The control circuit voltage is provided by a single phase machine tool transformer with a grounded secondary.

The 115V control circuit is fuse protected. The pump motor is controlled by a full voltage magnetic non-reversing motor starter, with overcurrent and thermal overload protection.

Automatic Vent

This feature automatically triggers a quick and complete purge of air from the system before you start the unit. The vent actuates the solenoid valve, and forces trapped air and water out through the drain, properly filling and priming the unit prior to startup. ***Complete venting is necessary to prevent damage to the pump and heater.***

Pressure Switch

A pressure switch built into each unit keeps the system from starting until the water supply is turned **On** and subjected to the minimum water supply pressure. This feature protects the pump seal and the heater from damage through attempted operation without water. The pressure switch is set at approximately 16 psig (110.32 kPa/1.10 bars) for 250°F (121°C) units or 55 psig (379.23 kPa/3.79 bars) for 300°F (149°C) units prior to leaving the factory.

4-2 The Microprocessor Controller

The controller is an easy-to-operate microprocessor-based PID control device. When the process reaches the set point, the PID control cycles the cooling valve and/or immersion heater to maintain the proper leaving water temperature.

The controller has been fully factory tested, and loaded with Preset tuning Parameters. To Quickly adapt the controller to your process, you may elect to tune the controller at Start-up. Refer to the Auto-tune section, 4-10.

Built-in range of operation on the controller is 0°F to 250°F (-18°C to 121°C).

Figure 7
Typical E5CK Microprocessor Controller

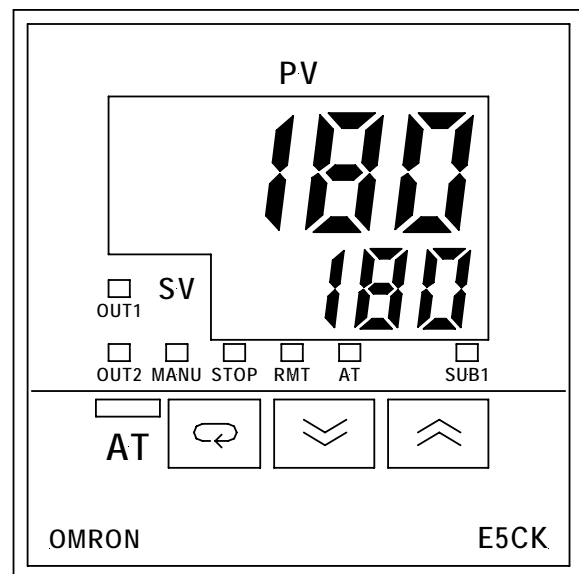

4-3 Controller Display

Figure 7

PV or Process Value Numeric LED

During normal operation, the large red **PV** Process Value LED on the controller displays the actual process temperature at the To Process thermocouple. It also lists parameter symbols during setup and error messages if an error occurs.

SV or Set Value Numeric LED

During normal operation, the green **SV** Set Value LED on the controller displays the process set point you want the chiller to maintain. It also displays parameter and pre-set function values during setup.

OUT1 LED

The orange **OUT1** LED lights when the controller output energizes the immersion heater.

OUT2 LED

The orange **OUT2** LED lights when the controller output energizes the cooling valve.

MANU LED

The orange **MANU** LED lights when you place the controller in Manual mode.

STOP LED

The orange **STOP** LED is not used.

RMT LED

The orange **RMT** LED is lit during remote operation.

AT LED

The orange **AT** LED flashes during auto-tuning.

SUB1 LED

The orange **SUB1** LED is lit during half/full heat temperature output.

4-4 Using Controller Keys

Figure 7

Note: Only those who are completely familiar with the unit controller should perform the operations described in Sections 4-4 through 4-14.



AT AT Key



Press and hold the **AT AT** key for two seconds to initiate *or* to stop the auto-tune function.



Display Key



The functions of the **Display** key change, based on how long you press it. Press the **Display** key for less than one (1) second to scroll through parameters within the mode. Press the **Display** key for at least one (1) second or more to display the menu; the Display function also lets you select the mode you need to adjust.

Important!

Do not change any of the control settings without consulting the AEC Service Department.

The AEC, Inc. warranty does not cover chiller failures from tampering with controller settings!

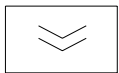

Down Key

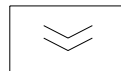

Each press of the **Down Arrow** key decrements or reduces the values or settings on the **SV** Set Value display.

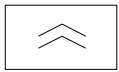

Up Key

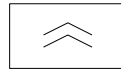

Each press of the **Up Arrow** key increments or advances the values or settings on the **SV** Set Value display.

Digital Flow Meter

Optional

The optional digital flow meter measures process flow in gallons per minute (gpm), or liters per min (lpm). Controls are set at the factory; no customer-usable control is necessary. Depending on option level and setup, flows can be measured at rates reaching and exceeding 60 gallons per minute (227 lpm).

Figure 8
 Typical Graphic and Button Panels; Optional Digital Flow Meter Shown

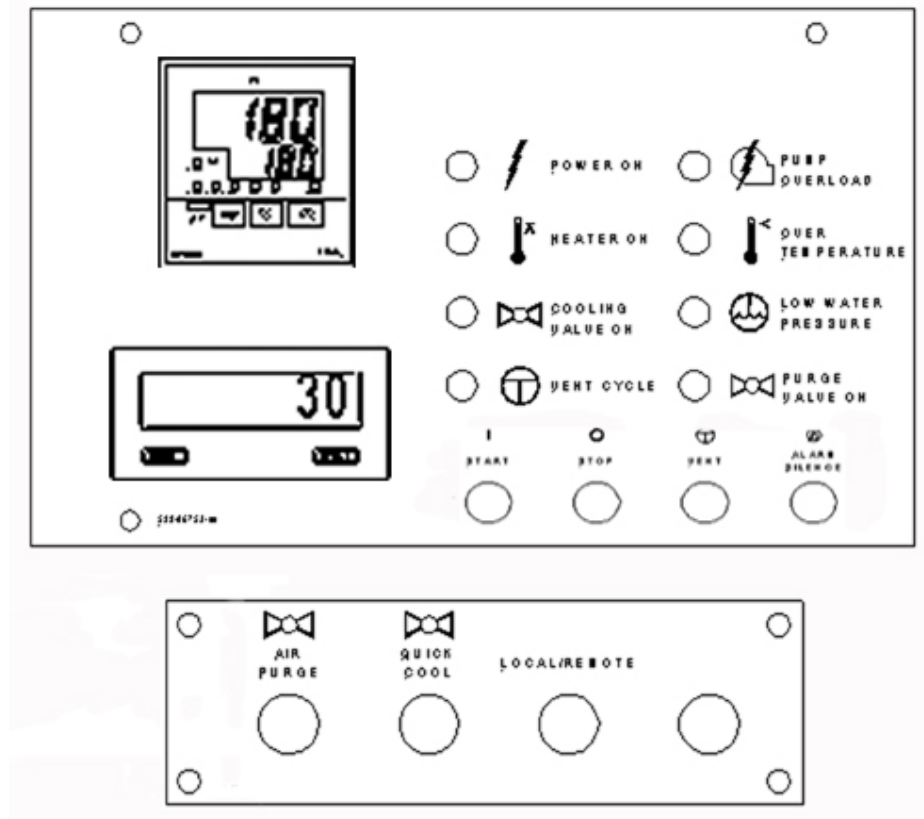

4-5 Identifying Graphic Panel Indicators

Figure 8

POWER ON Indicator

The green **POWER ON** indicator lights when the temperature control unit is energized.

PUMP OVERLOAD Indicator

The red **PUMP OVERLOAD** indicator lights if the pump motor overload opens from high amp draw. The pump motor contactor drops out, protecting the motor.

HEATER ON Indicator

The red **HEATER ON** indicator lights during heater operation. The **HEAT LED** on the controller lights at the same time.

OVER TEMPERATURE Indicator

The red **OVER TEMPERATURE** indicator lights if the process temperature rises above the safety thermostat setting.

COOLING VALVE ON Indicator

The green **COOLING VALVE ON** indicator lights during cooling valve operation. If the unit has a standard solenoid (not motorized) cooling valve, the **OUT 2** LED on the controller lights at the same time.

LOW WATER PRESSURE Indicator

The red **LOW WATER PRESSURE** indicator lights if cooling water pressure drops below 16 psig (110.32 kPa/11.03 bars). The pressure switch opens and shuts down the 115 VAC control power.

VENT CYCLE Indicator

The green **VENT CYCLE** indicator lights during vent cycle operation.

PURGE VALVE ON Indicator

Units with Optional System Purge

The amber **PURGE VALVE ON** indicator lights when the **AIR PURGE** switch is **ON**. This option purges water from the process. When control power is **OFF** and the **AIR PURGE** switch is pressed, the system purge solenoid and cool/vent valves open. Air displaces the water in the TrueTemp™ TCU system and the process piping, pushing the water out the **WATER OUT** line.

A check valve in the TrueTemp™ TCU system piping and a shutoff valve on the **Water In** line insure that the water has only one path to follow.

To activate system water purge:

1. Turn the unit off with the stop button on the graphic panel.
2. Close the **COOLING WATER IN** line shutoff valve.
3. Open the compressed air line shutoff valve.
4. Turn on the **AIR PURGE** switch.

When water no longer comes out of the cooling **WATER OUT** line and only air comes out, the purge is complete. *Use caution when removing these lines;* air pressure is still present inside.

4-6 Using Graphic Panel Buttons

Figure 8

START Button

Push the **START** button to energize the unit and begin the temperature control cycle.

STOP Button

Push the **STOP** button to de-energize the unit and stop the temperature control cycle.

VENT Button

Push the **VENT** button for additional manual venting. The **VENT CYCLE** indicator lights during the vent cycle.

ALARM SILENCE Button

Optional

Turn on **ALARM SILENCE** switch to silence the alarm. You should investigate the alarm condition and restore the unit to normal operation before continuing with the temperature control cycle.

AIR PURGE Button

Optional

Turn on the **AIR PURGE** switch to purge the system of air. The **PURGE VALVE ON** indicator lights during the air purge cycle.

QUICK COOL Button

Optional

Turn on the **QUICK COOL** switch to open the cooling valve and quickly cool the process.

LOCAL/REMOTE Button

Optional

Press the **LOCAL/REMOTE** button to toggle between local and remote temperature sensor probe operation.

4-7 Alarms

Audible/Visual General Fault Alarm

Optional

The audible/visual general fault alarm sounds if any fault triggers, such as low water pressure, over-temperature, or pump overload. A signal from any of the safety devices activates a horn and flashing strobe.

- Push the **ALARM SILENCE** button to silence the alarm.

The optional mechanical high temperature safety alarm is interlocked with the heater. When triggered, the heater cuts out and the pump continues to run.

4-8 Controller Internal Switches

The controller is set up and tested at the factory for optimum operation, and adjusting the internal switches is not necessary. If the controller does not work properly, or you suspect someone has accidentally changed some settings, there are two things to do. First, perform the Auto-Tune procedure described in Section 4-10 on Page 38. If that doesn't work, restore the controller to the original factory settings as described in Section 6-3 on Pages 50 to 57.

4-9 Controller Factory Setup

The controller is set up and tested at the factory for optimum operation, and in most cases doesn't need to be adjusted. If the controller does not work properly, or you suspect someone has accidentally changed some settings, you can do two things. First, perform the Auto-Tune Procedure described in the following section. If that doesn't work, restore the control to the original factory settings as described in Section 6-3 on Pages 50 to 57.

For your protection, all menu modes and levels except 0 and 1 are locked out at the factory. Level 2 is unlocked for units with factory-installed communications options.

4-10 Auto-Tuning the Controller

The Auto-Tune function lets you fine-tune the control PID to process requirements. Activate the Auto-Tune function whenever the process under control changes. Don't be alarmed by control response. It may take the process temperature above and below the

set points as many as three (3) times. It will then level off and control to the process set point. **Auto-tuning can take up to 45 minutes**, and is best done *before* any product is run.

To auto-tune the controller:



- Press and hold down the **AT AT** key for two (2) seconds until the **AT** indicator flashes.

The **AT** LED flashes to indicate that the control is tuning itself.

When the **AT** LED light stops flashing, the controller is tuned and ready for operation.



4-11 Changing from Fahrenheit to Celsius

Changing the control display from °F to °C is done in the Setup mode, which is pre-set and locked out at the factory. Contact AEC Customer Service if you need to change the display.

4-12 Operating the Unit with the Controller

Level 0 Mode

To change the process temperature set point:

- Press the  Down Arrow key to lower the set point to the temperature you want.
- Press the  Up Arrow key to raise the set point to the temperature you want.

The set point automatically updates after a two (2) -second display.

4-13 Selecting Half- or Full-Heat Operation

The controller is set at the factory for full-heat output as its default setting. The high heat output uses the Alarm 2 low deviation selection to enable the heater contactor.

To select half-heat operation:

1. Set **Level 1** mode:

- Press and hold the  **Display** key for two (2) seconds.

- Press the  **Up Arrow** key to increment the display to **1**.

- Press and hold the  **Display** key for two (2) seconds to gain access to Level 1.

2. Press the  **Display** key to display **AL-2**.

3. Press the  **Up Arrow** key to increase the **SV** set value from zero to plus ten (**0** to **+10**).

4. Return to **Level 0** for run condition:

- Press and hold the  **Display** key for two (2) seconds.

- Press the  **Down Arrow** key to increment the display to **0**, Level 0.

- Press and hold the  **Display** key for two (2) seconds to return to the normal **PV/SV** display screen.

4-14 Communications

A connection port on the electrical cabinet permits easy hook-up to the host computer for RS-232C and RS-485 communications. The connection port is a direct pin-to-pin extension from the back of the controller. For pin outs, consult the Communication Manual for the PID controller.

5

Startup and Operation

5-1 Introduction

The checklist below outlines start-up procedures for TrueTemp™ TCU Series water temperature control units. This list assumes that installation information located in this manual has been read and followed.

5-2 Startup Checklist

- ☑ Check the shipping papers against the serial tag to make sure that system size, type, and voltage is correct for the process under control.
- ☑ Check the transformer primary voltage connections to be sure they are configured for the electrical power you are using. The voltage at the main power connection must be within plus or minus ten percent ($\pm 10\%$) of the voltage listed on the serial tag. Electrical connections must conform to all applicable codes. Make sure that a qualified electrician checks all electrical connections.
- ☑ The safety thermostat is preset at the factory to 250°F or 300°F (121°C or 149°C), depending on configuration. It trips at 265°F or 315°F (129°C or 157°C), depending on configuration.
- ☑ The relief valve should be piped to an open, unrestricted drain.
- ☑ **TO PROCESS, FROM PROCESS, WATER IN, WATER OUT, and MOLD PURGE** connections should be complete.

! CAUTION

Only use components rated at a minimum of 150 psig and 250°F (1,034.25 kPa/10.34 bars and 121°C).

- ☑ All outer panels must be in place.
- ☑ All external process valving should be set for proper operation of the unit.

- ☑ Cooling and/or makeup water between 16 psig and 55 psig (110.32 kPa/1.1 bars and 379.23 kPa/3.79 bars) must be available for the unit to operate properly.
- ☑ Connect the main power to the unit disconnect switch, and press the **START** switch to check for proper pump rotation direction as described in Section 5-6 on Page 44. Pump rotation should be clockwise, viewed from the **motor** end.
- ☑ Check your work and proceed to the **Startup Procedure** section on the following page.

5-3 Starting the Temperature Control Unit

- ☑ Turn **ON** the water supply, and turn the rotary disconnect to the **ON** position.
- ☑ Press the start button on the graphic display
- ☑ The unit automatically executes a one-minute venting sequence to expel air trapped in the process piping. AEC, Inc. recommends a longer venting sequence on larger process systems. Press and hold the **VENT** button to force the cooling/vent valve open and eliminate air trapped in the process piping in larger process systems.

The controller is **OFF** and the **Vent Cycle** indicator is lighted during the vent sequence.

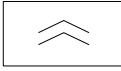
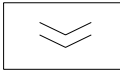
- ☑ Set the microprocessor controller to the process temperature you want by pressing the  **Up Arrow** button or the  **Down Arrow** button on the front of the controller.

- ☑ Allow your process to reach the set point temperature, then auto-tune the control by pressing the **AT** key. See Section 4-10 on Page 37 for more information.
- ☑ Watch the drain for any bubbles or erratic flow, which indicates if the system has been properly vented. If the stream is steady, the unit was properly vented and all air is out of the system.
- ☑ Operate the unit, checking for anything unusual that could indicate improper operation.

Note: You can stop the TrueTemp™ TCU Series temperature control unit at any time by pressing the **STOP** button. It's programmed to cool the TCU to 150° F (66° C) before stopping the TCU to prevent damage to the pump seal.

! CAUTION

1) Your TrueTemp™ TCU system operates with hot water under pressure. To reduce the risk of scalding:



- Always wear work gloves and safety glasses when operating the unit.
- Never operate the unit with panels or shields removed.
- Pipe the relief valve to an open drain.
- Never install a fitting or hose that is rated less than 150 psig and 250°F (1,034.25 kPa/10.34 bars and 121°C).

2) To reduce the risk of electrical shock:

- All electrical installation and repairs should be done by a qualified electrician.
- Ground the unit in accordance with electrical codes.
- Never attempt any repairs without first opening and locking out the main disconnect.
- Never deactivate or neutralize any safety device.

5-4 Operating the Unit with the Controller

To change the process temperature set point:

- Press the  Down Arrow key to lower the set point to the temperature you want.
- Press the  Up Arrow key to raise the set point to the temperature you want.

5-5 Sequence of Operation

The simplicity of design and the highly engineered controller make this unit almost self-operating. The **START**, **STOP**, and **VENT** buttons and the temperature controller buttons are all that is required to operate this unit.

After you complete all connections, turn the water supply **ON**, then turn control power **ON**. The unit automatically vents for a preset time of one (1) minute. If you need additional vent time, press the **VENT** button on the control panel.

As the water comes in the water supply line, the water must enter the pump, up through the tank and out through the delivery line, through the process, back through the return line, and through the solenoid line and out the drain line.

At this time, watching the drain for bubbles or erratic flow will indicate whether or not the system has been properly vented. If a steady stream flows from the drain line, it is certain that all the air is out of the system.

- ☑ TCU systems provide temperature control on processes by directly heating the process water and injecting cooling water into the process water.
- ☑ When the unit is energized, the pump starts and a one minute vent sequence opens the cooling/vent valve to remove any air trapped in the process piping.
- ☑ If the cooling water supply pressure is insufficient, the low cooling water pressure cutout switch (set at 16 psig, 10 psig differential [110.32 kPa/1.10 bars, 68.95 kPa/0.69 bars differential]) opens, the **LOW WATER PRESSURE** indicator lights, and the unit does not operate until the pressure is 16 psig (110.32 kPa/1.10 bars) or more. **You need at least 16 psig** (110.32 kPa/1.10 bars) for the best cooling capacity and to prevent water boiling in the process circuit at high temperatures, particularly at the pump suction.
- ☑ After venting, the microprocessor controller monitors the **TO PROCESS** sensor, cycling open the cooling/vent valve to discharge warm water or energizing the immersion heater to maintain the process set temperature.

5-6 Checking Motor Rotation Direction

Check for correct pump rotation direction by looking at the motor impeller. Press the **START** button and the **STOP** button, and note the direction that the motor turns. Rotation should be **clockwise** when viewed from the motor end.

Note: Make sure that a qualified electrician performs the following steps.

To change rotation direction:

1. Disconnect and lock out power at the fused disconnect.
2. Reverse any two incoming leads at the power terminal blocks.
3. Do not switch leads at the motor or motor starters.

5-7 Shutting Down the Temperature Control Unit

Cool the unit down by selecting a set point of zero (0). Let the unit stabilize at one temperature close to the incoming water temperature, then press the **STOP** button. Now press the **VENT** button to relieve any remaining pressure in the system.

- Notes -

! CAUTION



Never attempt to service a unit until a qualified electrician has opened and locked out the main disconnect using OSHA 1910.147 standards.

The water supply should be turned off and internal pressure should be relieved before you remove panels.

All electrical connections must be done by a qualified electrician.

! WARNING



Disconnect all power to the unit, let the unit cool down, and turn off the water *prior to any servicing*.

Failure to do so can result in SERIOUS INJURY OR DEATH!

6-1 Preventive Maintenance

Draining

Drain the TCU thoroughly if you are taking it out of service for a long period of time, or you expose it to freezing. Drain plugs are provided at the base of the heater tank and at the base of the pump pedestal.

Periodic Checks

Every Six Months

Inspect all electrical connections for secure attachment and for safe and secure ground connections. Inspect the power cable, especially at the entrance point to the unit. This inspection should be made by a qualified electrician. Check for leaks, especially under the pump, as it may indicate a worn pump seal.

6-2 Corrective Maintenance

Pumps and Seals

Before leaving our factory, we test each unit extensively, then we calibrate each unit. Afterwards, the unit is drained and blown out with air to remove water from piping systems. If the unit is allowed to stand idle for a long time before being installed in your factory, the housing gasket at the pump can dry out and can possibly leak when the unit is started. In most cases these gaskets will soon swell and form a tight seal. In other cases, it may be necessary for you to tighten the pump bolts to stop a leaking condition.

Pump seal surfaces can separate slightly because of rough handling or from vibration during transit. This could cause a leak at the pump seal when the pump is started, but in most cases the surfaces will mate again after the pump is allowed to run for a short period of time. If they do not reseal, you may need to open the pump and free the seal by hand. It is seldom necessary to install a replacement seal in a new unit unless the seal has been damaged because the unit was started without water.

Our pump seals have a long period of service life. Some conditions, of course, can shorten seal life, including the presence of grit, operation of the unit without water, sustained high water temperature, or presence of certain chemicals in the water. Our pump seal assembly has been developed to resist abrasive particles that are present in many water systems. This is done by a special flushing system that uses water exiting the pump to constantly wash the seal area.

It is also fitted with high temperature flexible components for maximum heat resistance. These same components remain flexible even at low temperatures. Thus, the standard seal is a fine combination of heat resistant and wear resistant components. Unfortunately, even under normal use, the seal will eventually wear and require replacement.

A small puddle underneath the unit is a sign of rotary seal wear, and if investigation confirms the pump as the source, the seal should be replaced as soon as practical. The water slinger is intended to provide temporary protection against this, but a continued and substantial leak will ruin the motor bearing and cause further damage.

After the unit has been in service for a period of years where abrasive conditions are present, you may find that the pump bracket (the top half of the pump casting), can be eroded away in the area around the seat of the rotary seal. This area should provide a straight, smooth bearing surface for the cup seal. Should your casting show signs of erosion in this area, the casting needs to be replaced. The replacement cost of the casting is very modest compared to the down time and maintenance cost for frequently replacing the seal.

Under some conditions, the pump may not start. After turning off the power supply, check the motor shaft to be certain it is free to turn. By removing the drip cover on top of the motor, you'll have access to the end of the shaft. It has been slotted to make it easy to turn with a screwdriver. If the shaft is free to turn, next check that the motor overloads are set, check for blown fuses, and finally check the power supply on each leg to the motor. A qualified electrician should check the motor and its circuit.

Important!

If the pump motor wiring is disconnected for removal from the unit, make sure that you check the actual rotation direction when the motor is rewired to the unit.

A phase sensor does not always indicate proper rotation if motor wire leads are reversed at installation.

Consult the elementary wiring diagram for more information.

Heaters

Heaters may need to be cleaned chemically or mechanically to remove deposits and dirt that reduce heat transfer and cause hot spots. Hot spots cause premature heater failure. Install a new gasket when reassembling. Make sure a qualified electrician disconnects and reconnects heater wires.

Solenoid Valves

- ☑ Clean annually, more often if using high mineral content water or on high service level units.
- ☑ Sluggish operation, excessive leakage, and/or noise indicate cleaning is necessary. Inspect the components for excessive wear while the valve is disassembled.
- ☑ Rebuild kits are available from the AEC, Inc. Parts Department.

6-3 Restoring the Controller to Factory Setup

If the preset parameters on the controller have been tampered with and it no longer properly controls temperature, you can restore the controller to factory setup parameters.

E5CK Operating Parameters

The E5CK controller has several mode selections. Within each mode are numerous parameters that can be set.

Before you can gain access to the several modes of operating parameters, you must change the security lock-out of the controller. AEC sets the security level at the factory to protect the parameters from being accidentally changed. The explanation that begins on the following page is how to change operating modes, how to change out the security level, and how to reset AEC factory default settings.

Available E5CK Modes

Menu Display

Level 0 Mode

For normal operation. Execute **AT** auto-tuning, change to Manual mode.

Level 1 Mode

For adjusting primary control parameters. Execute: Set alarm values; set the control period; set PID parameters.

Level 2 Mode

For adjusting secondary control parameters. TrueTemp™ TCU units use E5CK default settings.

Setup Mode

For setting basic specifications. Set parameters for input type, scaling, output assignments and direct/reverse operation.

Expansion Mode

For setting expanded functions. Set: **ST** (self-tuning), **SP** setting limiter. Select: advance PID or **ON/OFF** control.

Option Mode

This mode is only accessible when an option board is installed.



Calibration Mode

For calibrating communication unit E53-CKF. Not used.

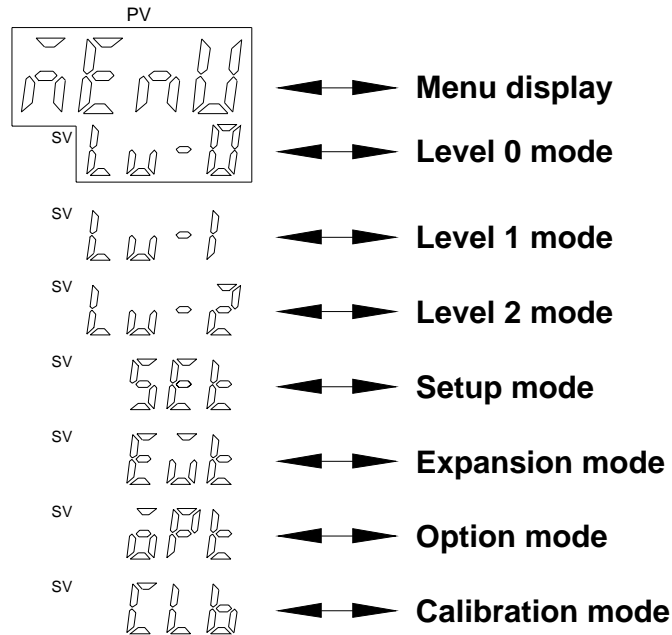
Figure 9
Display Readout for Mode Settings



Setting E5CK Security in Protect Mode

1. To access protect mode, press and hold the **AT** AT key  and the  Display key for two (2) seconds.
2. The display should read **SECr** for security mode. If you press the  Display key for short presses you will toggle between **SECr** and **KEYP** for **AT** protect.

- With the display reading **SECr**, set the security levels by the arrow up and down keys. Change the security level to 1 to make changes to the operating parameters. TrueTemp™ TCU units are factory set to Security Level 5.

Available Security Levels

Mode	Security level						
	0	1	2	3	4	5	6
Calibration	X						
Option	X	X					
Expansion	X	X					
Setup	X	X					
Level 2	X	X	X				
Level 1	X	X	X	X			
Level 0	X	X	X	X	X	X	

To return to the main display (run mode), press and hold the AT and Display key for 2 seconds.

Entering Operating Parameters to Select Modes

To enter the menu display:

- Press the  **Display** key for two seconds.

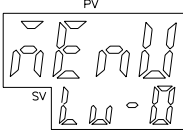





The screen displays .

- Press the  **Up Arrow** key to toggle through the different modes.

The **SV** readout displays the mode you selected.

- To switch parameters within a mode, press the  **Display** key once more for two (2) seconds.

The **PV** readout displays the different parameters within each mode.

4. Use short presses on the  **Display** key to display each parameter within a mode.
The **SV** readout displays the different values for the parameter within a mode.
5. Press the  **Down Arrow** key to lower values of a parameter; press the  **Up Arrow** key to raise values of a parameter.
6. Press the  **Display** key for about two (2) seconds to move up a level back into the different modes.
7. Press the  **Down Arrow** key until Level 0 displays.
8. Press the  **Display** key for about two (2) seconds to go to Operating mode.

E5CK Factory Setting for Process Temperature



1. Remove controller from housing and check for output board number E53-R4R4 (Relay/ Relay).
2. Make sure jumper setting for input type is set for thermocouple TC-PT, middle jumper.
3. Return controller to housing.
4. Press the  **Display** key for one (1) second to enter Menu Display.
5. Press the  **Up Arrow** key to get to Setup mode; the screen displays the **SET** message.
6. To switch parameters within Setup mode, press the  **Display** key.

Figure 10
Setting List for Process Temperature Controller

Mode	Parameter	Setting range	Default	AEC setting
Protect	SECr Security	0 to 6	1	5
Protect	KEYP A/M Key protect	ON/OFF	OFF	ON
Level 0	PV/SV display	—	—	—
Level 0	Switch to Manual mode	-5.0 to 105.0%	0.0	Default
Level 0	MV monitor	Cannot be set	0.0	Default
Level 0	r-S Run/Stop	Run/Stop	Run	Default

Mode	Parameter	Setting range	Default	AEC setting
Level 1	At AT Execute/Cancel	OFF/AT-1/AT-2	0	Default
Level 1	SP-0 Set point 0	Set point lower limit to Set point upper limit	0	Default
Level 1	SP-1 Set point 1	Set point lower limit to Set point upper limit	0	Default
Level 1	AL-1 Alarm value 1	-1999 to 9999 EU	0	0=full heat, +10=half heat
Level 1	AL-2 Alarm value 2	-1999 to 9999 EU	0	3
Level 1	AL-3 Alarm value 3	-1999 to 9999 EU	0	0
Level 1	P Proportional band	0.1 to 999.9% FS	10.0	5
Level 1	I Integral time	0 to 3999 SEC	233	55
Level 1	d Derivative timer	0 to 3999 SEC	40	9
Level 1	C-SC Cooling coefficient	0.01 to 99.99	1.00	Default
Level 1	C-db Dead band	-19.99 to 99.99	0.00	Default
Level 1	oF-r Manual reset valve	0.0 to 100.0	50.0	Default
Level 1	HYS Hysteresis (heat)	0.01 to 99.99	0.10	Default
Level 1	CHYS Hysteresis (cool)	0.01 to 99.99	0.10	Default
Level 1	CP Control period (heat)	1 to 99 SEC	20	15
Level 1	C-CP Control period (cool)	1 to 99 SEC	20	20

Figure 10
Setting List for Process Temperature Controller (Cont'd.)

Mode	Parameter	Setting range	Default	AEC setting
Level 2	Remote/Local	Only active with comm. board	Local	Default
Level 2	SPrU Sp Ramp Time Unit	M(Minutes)/H(Hours)	M	Default
Level 2	SPrt Sp Ramp Set Value	0 to 9999 EU	0	Default
Level 2	Mu-5 MV at Stop	-5.0 to 105.0%	0.0	Default
Level 2	Mu-E MV at PV Error	-5.0 to 105.0%	0.0	Default
Level 2	OL-H MV Upper Limit	MV Lower Limit +0.1 to 105%	105.0	Default
Level 2	OL-L MV Lower Limit	-5.0 to MV Upper Limit -0.1%	-5.0	Default
Level 2	OrL MV Change Rate Limit	0.0 to 100.0%/SEC	0.0	Default
Level 2	InF Input Digital Filter	0 to 9999 SEC	0	Default
Level 2	ALH2 Alarm 2 Hysteresis	0.01 to 99.99%	0.02	Default
Level 2	In5H Input Shift Upper Limit	-199.9 to 999.9 °C	0.0	Default
Level 2	In5L Input Shift Lower Limit	-999.9 to 999.9 °C	0.0	Default

Mode	Parameter	Setting range	Default	AEC setting
Setup	In-t Input Type	0 to 21	2	2
Setup	d-U °C/F Selection	°C/F	°C	°F
Setup	InIt Parameter Initialize	Yes/No	No	Default
Setup	OUt1 Control Output 1 Assignment	Heat/Cool/Alarm 1/Alarm 2/Alarm 3/LBA	Heat	Default
Setup	OUt2 Control Output 2 Assignment	Heat/Cool/Alarm 1/Alarm 2/Alarm 3/LBA	Cool	Cool
Setup	Sub 1 Auxiliary Output 1 Assignment	Alarm 1/Alm 2/Alm 3/LBA/S.ERR/E333	AL-1	AL-2
Setup	ALt1 Alarm 1 Type	0 to 11	2	Default
Setup	AL1n Alarm 1 open in alarm	NO/NC	NO	Default
Setup	ALt1 Alarm 2 Type	0 to 11	3	3
Setup	AL2n Alarm 2 open in alarm	NO/NC	NO	Default
Setup	6rEu Direct/Reverse Operation	OR-R/OR-D	OR-R	Default

Figure 10
Setting List for Process Temperature Controller (Cont'd.)

Mode	Parameter	Setting range	Default	AEC setting
Expansion	SL-H Set Point Upper Limit	SP Lower Limit +1 to Scaling Upper Limit	1300	250°F; 300°C opt.
Expansion	SL-L Set Point Lower Limit	Scaling Upper Limit to SP Lower Limit	-200	0
Expansion	CntL PID/ON/OFF	PID/ON/OFF	PID	Default
Expansion	SE ST Adaptive Tuning (Fuzzy)	OFF/ON	OFF	ON
Expansion	St Stable Range	0.1 to 999.9 °C/F	15	Default
Expansion	ALFA α	0.01 to 1.00	0.65	Default
Expansion	At-G AT Calculated Gain	0.1 to 10.0	1.0	Default
Expansion	rESt Standby Sequence Reset Setting Method	0/1	0	Default
Expansion	rEt Automatic Return of Display Mode	0 to 99 SEC	0	Default
Expansion	AT-H AT Hysteresis	0.1 to 9.9% FS	0.2	Default

Communications Option

Mode	Parameter	Setting range	Default	AEC setting
5bit	Communications stop bit	1 to 2	2	2
LEn	Communications data length	7 to 8	7	7
Prty	Communications parity	None, Even, Odd	Even	Even
bPS	Communications baud rate	1.2, 2.4, 4.8, 9.6, 19.2 K	9.6	9.6
U-nö	Communications unit number	0-99	0	0

Transfer Output

Mode	Parameter	Setting range	Default	AEC setting
tr-t	Transfer output type	SP, PV, SP RAMP, MV	PV	PV
tr-H	Transfer output upper limit	-200 to 1300	1300	250
tr-L	Transfer output lower limit	-200 to 1300	-200	0

6-4 Electrical Connections

Make sure that a qualified electrician inspects all electrical components and connections every six (6) months for secure attachment and ground connections. Inspect all wiring for fraying or damage, especially power lines where they enter the unit. **All wiring connections must be *tight*.**

Figure 11
Process Temperature Control Error Messages Table

Message	Cause	Control output		Alarm output
		With output unit other than current output unit	With current output unit	
FFFF	Input temperature has risen beyond the upper limit of the temperature range by more than 68°F (20°C) ①	OFF during reverse (heating) action, ON during normal cooling action.	4 mA during reverse (heating) action, 20 mA during normal (cooling) action.	Issues alarm outputs in accordance with the set alarm mode.
----	Input temperature has fallen below the lower limit of the temperature range by more than 68°F (20°C) ②	ON during reverse (heating) action, OFF during normal (cooling) action.	20 mA during reverse (heating) action, 4 mA during normal (cooling) action.	Issues alarm outputs in accordance with the set alarm mode.
SErr	The thermocouple has burned out or the short circuit bar has been removed. The platinum RTD has burned out or A and B have been short circuited.	OFF	Approximately 1 mA	Issues alarm outputs in accordance with the set alarm mode. Proportional alarm output is OFF.
E111 E333 (flashes)	Memory failure (E111) or analog to digital converter failure (E333) has occurred. Temperature controller must be repaired if recovery is not made by turning power off once and on again.	OFF	Approximately 1 mA	OFF

- ① When a Type J thermocouple is used, this error message is not displayed until the temperature has risen above the normal operating temperature operating range by more than 158°F (70°C).
- ② When a platinum RTD sensor is used, this message is displayed when the temperature has fallen to -147.82°F (-99.9°C).

6-5 Safety Devices

Caution!

Make sure that only qualified electricians test safety devices!

Safety devices should be tested for function **every six (6) months**. Perform the following procedures for testing:

Motor Overload

Disconnect main power. Open the electrical enclosure and rotate the manual **TEST** button on the motor overload to the tripped position. Close the enclosure and reconnect main power. Push the **START** button. The unit should **not** start and the **Pump Overload** indicator should illuminate.

Press the **RESET** button. The unit is now ready for operation.

Pressure Switch

With the unit running, program a set point of 30°F (-1°C). Allow the process temperature to drop under 100°F (38°C). When the process temperature reaches that point, turn off the water supply. The pump should stop and the Low Water Pressure indicator should illuminate. Turn the water supply on to reset the pressure switch.

Adjusting the Pressure Switch

The pressure switch used in your Royal Series water temperature control unit is factory set at 16 psig (110.3 kPa/1.1 bars). However, if the process does not require the unit to operate at 250°F (121°C), you can adjust the switch to meet your process needs.

Tools Required

- Small flat blade screwdriver
- #2 Phillips head screwdriver

! CAUTION	
	<p>HAZARDOUS ELECTRICAL CURRENT PRESENT.</p> <p>Maintain a safe ground and disconnect the power supply before servicing the unit.</p> <p>Make sure a qualified electrician makes electrical connections; disconnect/lock out electricity using OSHA 29CFR 1910.147 standards when servicing the unit.</p>

To adjust the pressure switch:

- Using a small, flat-blade screwdriver, carefully remove the plug at the top of the switch.

Figure 12
Pressure Switch
Side View and Top View

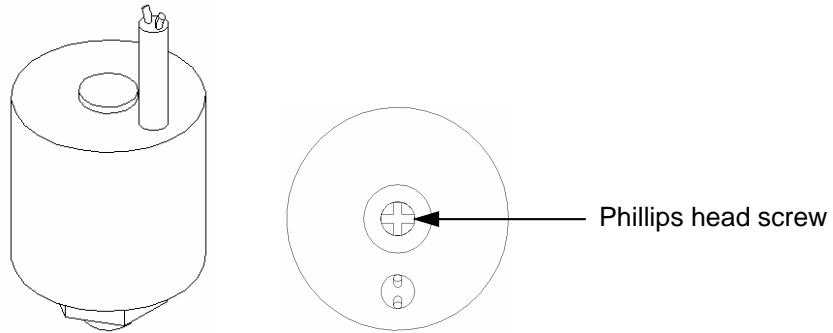

Under the plug is a Phillips-head adjusting screw:

- Turn the screw **counterclockwise** to **reduce** the pressure.

- or -

- Turn the screw **clockwise** to **increase** the pressure.

A quarter turn (90° rotation) approximates 15 psi (103.4 kPa/ 1.0 bars).

- Replace the plug on the top of the switch.

If the plug gets damaged, the switch is still sealed internally.

Make sure that the high limit on the controller is set to the values listed in the following table, based on the switch adjustment. This prevents the pump from cavitating and damaging the seal, the switch, and heater element(s).

psig	kPa	Max. temp. °F	Max. temp. °C
5 psig	34.4 kPa	227°F	108°C
10 psig	68.9 kPa	240°F	116°C
15 psig	103.4 kPa	250°F	121°C

Safety Thermostat

Disconnect main power. Open the electrical enclosure and disconnect the neutral lead on the safety thermostat from the terminal strip. Protect the stripped lead to prevent short circuits. Close the enclosure, reconnect main power, and push the **START** button. The heater should **not** turn on and the **Over Temperature** indicator should illuminate. **Disconnect main power before reconnecting the thermostat lead.**

6-6 Cleaning and Storage

- **Inspect the unit daily for leaks.** Wipe down the unit periodically to remove dirt and dust buildup, especially the motor casing.
- Drain and flush the unit every six (6) months to remove sediment buildup.
- Completely drain the unit and **carefully** blow out the piping with pressurized air before placing the unit in storage.

Condition	Possible cause	Solution
Unit does not turn on.	No power.	Check main disconnect, fuses, wiring, and power lead to unit.
	Wrong voltage supplied to unit.	Voltage must be within plus or minus 10% of nameplate rating.
	Defective on/off switch.	Replace.
	Control circuit fuse blown.	Replace.
	Defective control transformer.	Check transformer.
Unit does not run.	Broken or loose wire in pump motor control circuit.	Locate and repair.
	Pump motor contactor holding coil is open.	Repair or replace.
	Low water pressure light on.	Check for at least 16 psig (110.32 kPa/1.1 bars) water pressure on WATER IN or CITY WATER MAKEUP .
	Water supply to unit is turned off.	Open water supply.
	Pump overload light on.	Reset and test each leg for balanced amp draws.
Low pump pressure.	Pump running in reverse.	Verify proper rotation. If not clockwise, reverse any two incoming power leads.
	Foreign matter in the system.	Clean the system.
	System has minimal back pressure, and is operating at the far end of the pump curve.	As long as there is satisfactory process temperature control there is no problem.
High pump pressure.	Foreign matter obstructing system.	Clean the system.
	Restricted water flow.	Check for closed valves etc. Be sure all lines are properly sized.
	System has high back pressure, and is operating at the near end of the pump curve; a low flow condition.	As long as there is satisfactory process temperature control there is no problem.

Condition	Possible cause	Solution
Pressure switch circuit is open.	Insufficient cooling or makeup water pressure.	Check for 25 psig (172.38 kPa/1.72 bars) water pressure on WATER IN or CITY WATER MAKEUP .
	Switch is broken.	Jump power across switch and see if unit starts. Replace switch if needed.
Temperature fluctuations/ rapid cycling from hot to cold.	Undersized connectors/ water lines.	Increase size of connectors/ water lines.
	Long connecting lines between unit and mold.	Move the unit closer to the mold and shorten connecting lines.
	Serpentine flow through mold.	Connect lines for parallel flow instead of series flow.
	Blocked water line in mold.	Check mold for metal chips or lime buildup. Clean mold.
	Quick disconnect fitting with check valve.	Remove and replace fitting or valve.
	Lime buildup in unit piping.	Clean or replace.
	Faulty TCU.	Check unit by connecting 3/4" line directly from delivery to return line. Run unit to determine if TCU controls set point temperature.
Unit overheats or does not cool.	Drain is plugged or excessive back pressure is in drain line.	Clear drain line or eliminate back pressure condition.
	Faulty solenoid valve.	Test solenoid valve by pressing VENT button and listen for valve operation. Replace if faulty.
	Controller Cool output relay open.	Replace output relay.
	Solenoid valve is not operating, but COOL LED is on.	Set process temperature to minimum and check for magnetism on solenoid coil top.
	Solenoid coil circuit is open.	Check coil resistance. If MΩ range, replace solenoid coil.
	Modulating valve is not operating, but OUT2 LED is on.	Set process temperature to minimum and check for complete travel of valve.
	Insufficient pressure differential between cooling WATER IN and OUT lines.	Find a means to get less back pressure in the WATER OUT line.
	Cooling valve is undersize.	Replace cooling valve with a larger valve.

Condition	Possible cause	Solution
Unit does not heat/cannot achieve set point.	Defective heater contactor.	Visually inspect coil and contacts; repair/replace defective contactors.
	Defective immersion heater.	Check resistance on all three (3) legs of the heater with an ohm meter. If not all equal, contact factory for replacement heater.
	Controller heat output open.	Check the heater output with an ohm meter to ground. It should read in the mega-ohm range. Infinite or zero readings indicate a defective output.
	Heater contactor is not energizing, but HEAT LED is on.	Set process temperature to maximum and check for control voltage at heater contactor.
	Immersion heater elements dirty.	Remove heater and clean elements.
	Immersion heater element is burned out.	Check heater tank for scorched/discolored paint. Check resistance on all three (3) legs of the heater with an ohm meter. Replace heater as required.
		Check for balanced amp draws, and supply voltage. If not present replace immersion heater.
	OUT1 indicator is on, but no voltage on heater contact.	Replace relay board on controller.
	Cooling valve is leaking.	Dismantle valve and clean out.
	Solenoid valve is not operating, but COOL LED is on.	Set process temperature to minimum and check for magnetism on top of solenoid coil.
Magnetism on coil.	Clean coil.	
Faulty/dirty solenoid valve.	Press VENT button several times to flush the valve.	
Relief valve leaks.	Foreign material under valve seat.	Manually open valve to clear seat of material.
	High system pressure.	Reduce WATER IN or MAKEUP water pressure.
Unit runs continuously cooling or heating, and cannot attain set point.	Unit under-sized for application.	Call sales representative.

- Air Purge button, 36
- Alarm Silence button, 36
- Alarms, 36–37
- AT key, 33
- AT LED, 32
- Audible/visual general fault alarm, 37
- Automatic vent, 30
- Auto-tuning the controller, 38
- Available options, 9–10

- Button panel, 34

- Checking motor rotation direction, 44
- Cleaning and storage, 61
- Closed circuit/direct injection connections, 20
- Communications, 40
- Communications option list, 57
- Controller display, 31
- Controller factory setup, 37
- Controller internal switches, 37
- Controller keys, 32–34
- Controller operation, 38
- Cooling regulation, 30
- Cooling Valve On indicator, 35
- Cooling water connections, 21
- Copyright information, 2
- Corrective maintenance, 48–50
- Cutout switch, low pressure, 28

- Deionized water applications, 20
- Digital flow meter, 33
- Disclaimer information, 2
- Display key, 33
- Display readout for mode settings, 52
- Distilled water applications, 19
- Down key, 33
- Draining, 47
- Drawing, 11

- E5CK modes, 51
- E5CK operating parameters, 50
- E5CK security, 52
- Electrical connections, 24, 58
- Electrical subpanel, 26
- Electricals, 30
- Expansion tank, 21
- External piping sizing considerations, 17

- Fahrenheit to Celsius, 38

- General information
 - Available options, 9–10
 - Models covered, 8
 - Necessary documents, 7–8
 - Standard features, 9
- Graphic and button panels, 34
- Graphic panel, 34
- Graphic panel buttons, 36
- Graphic panel indicators, 34–35

- Half- or full-heat operation, 39
- Heater contactor, 29
- Heater On indicator, 34
- Heaters, 28
- High-mobility piping considerations, 19

- Identifying controls and displays
 - Controller internal switches, 37
- Identifying controls and features, 27–40
 - Alarms, 36–37
 - Auto-tuning the controller, 38
 - Communications, 40
 - Controller display, 31
 - Controller factory setup, 37
 - Controller keys, 32–34
 - Controller operation, 38
 - Fahrenheit to Celsius, 38
 - Graphic panel buttons, 36
 - Graphic panel indicators, 34–35
 - Half- or full-heat operation, 39
 - Identifying mechanical controls and features, 27–31
 - Microprocessor controller, 31
- Identifying mechanical controls and features, 27–31
- Incomplete shipment, 14
- Incorrect shipment, 14
- Installation information, 17–26
 - Cooling water connections, 21
 - Electrical connections, 24
 - External piping sizing considerations, 17
 - High-mobility piping considerations, 19
 - Location considerations, 17
 - Permanent piping considerations, 18
 - Process approach temperature considerations, 17
- Process water connections, 20
- Process water considerations, 19
- System purge connections, 22

- Local/Remote button, 36
- Location considerations, 17
- Low pressure cutout switch, 28
- Low Water Pressure indicator, 35

- Maintenance
 - Cleaning and storage, 61
 - Corrective maintenance, 48–50
 - Draining, 47
 - Electrical connections, 58
 - Heaters, 50
 - Motor overload, 59
 - Periodic checks, 48
 - Pressure switch, 59
 - Preventive maintenance, 47
 - Pumps and seals, 48
 - Restoring the controller, 50–57
 - Safety devices, 58–61
 - Safety thermostat, 61
 - Solenoid valves, 50
- MANU LED, 32
- Microprocessor controller, 31
- Models covered, 8
- Motorized modulating valves, 29

- Necessary documents, 7–8

- Operation, 43
- Options, 9–10
- OUT1 LED, 32
- OUT2 LED, 32
- Over Temperature indicator, 35

- Periodic checks, 48
- Permanent piping considerations, 18
- Pipe sizes for ¾ hp to 7½ hp units, 18
- Power On indicator, 34
- Pressure drops, 23
- Pressure relief valve, 27
- Pressure switch, 31
- Preventive maintenance, 47
- Process approach temperature considerations, 17

Process temperature control
 error messages, 58
 Process temperature factory
 setting, 54
 Process water connections, 20
 Process water considerations,
 19
 Pump curves
 50 Hz pump curves, 23
 60 Hz pump curves, 23
 Pump Overload indicator, 34
 Pump starter, 29
 Pumps, 28
 Pumps and seals, 48
 Purge Valve On indicator, 35
 PV LED, 31

 Quick Cool button, 36

 Raw water treatment, 19
 Restoring the controller, 50–57
 Returns, 14
 Revision number, 2
 RMT LED, 32

 Safety considerations, 3
 Safety devices, 58–61

 Safety thermostat, 27
 Sequence of operation, 43
 Setting list for process
 temperature controller, 55
 Shipping damages, 13
 Shipping information, 13–15
 Incomplete shipment, 14
 Incorrect shipment, 14
 Returns, 14
 Shipping damages, 13
 Uncrating, 15
 Unpacking and inspection, 13
 Shock stop, 29
 Shutting down the unit, 45
 Solenoid valves, 28
 Specifications, 12
 Standard features, 8–9
 Start button, 36
 Starting the unit, 42
 Startup and operation, 40–45
 Checking motor rotation
 direction, 44
 Operation, 43
 Sequence of operation, 43
 Shutting down the unit, 45
 Starting the unit, 42
 Startup checklist, 41

 Startup checklist, 41
 Stop button, 36
 STOP LED, 32
 SUB1 LED, 32
 Subpanel, 26
 SV LED, 32
 System purge connections, 22

 TCU drawing, 11
 TCU specifications, 12
 Thermocouple, 27
 Thermostat, 27
 To Process thermocouple, 27
 Transformer, 29
 Troubleshooting, 62–64
 Typical piping schematic, 22

 Uncrating, 15
 Unpacking and inspection, 13
 Up key, 33

 Vent button, 36
 Vent Cycle indicator, 35

 Water hammer arrestor, 29



Parts Department

Call toll-free 7am–6pm CST [800] 423-3183 or call [847] 273-7700

The Parts Department at AEC, Inc. is ready to provide the parts to keep your systems up and running. AEC replacement parts ensure operation at design specifications. Please have the model and serial number of your equipment when you call. Consult the Customer Parts List included in your information packet for replacement part numbers.



Service Department

Call toll-free 8am–5pm CST [800] 233-4819 or call [847] 273-7700

Emergencies after 5pm CST, call [847] 439-5655

AEC has a qualified service department ready to help. Service contracts are available for most AEC products.



Sales Department

Call [847] 273-7700 Monday–Friday, 8am–5pm CST

AEC products are sold by a world-wide network of independent sales representatives. Contact our Sales Department for the name of the sales representative nearest you.



Contract Department

Call [847] 273-7700 Monday–Friday, 8am–5pm CST

Let AEC install your system. The Contract Department offers any or all of these services: project planning; system packages including drawings; equipment, labor, and construction materials; and union or non-union installations.



AEC, Inc.

1100 Woodfield Rd Suite 588

Schaumburg IL 60173

[847] 273-7700 • Fax [847] 273-7804