

## Water Manifold & Flow Control Devices

Renmar have now added a quality range of products to assist with the distribution of water around the mould tools, together with mechanical and digital flow devices.

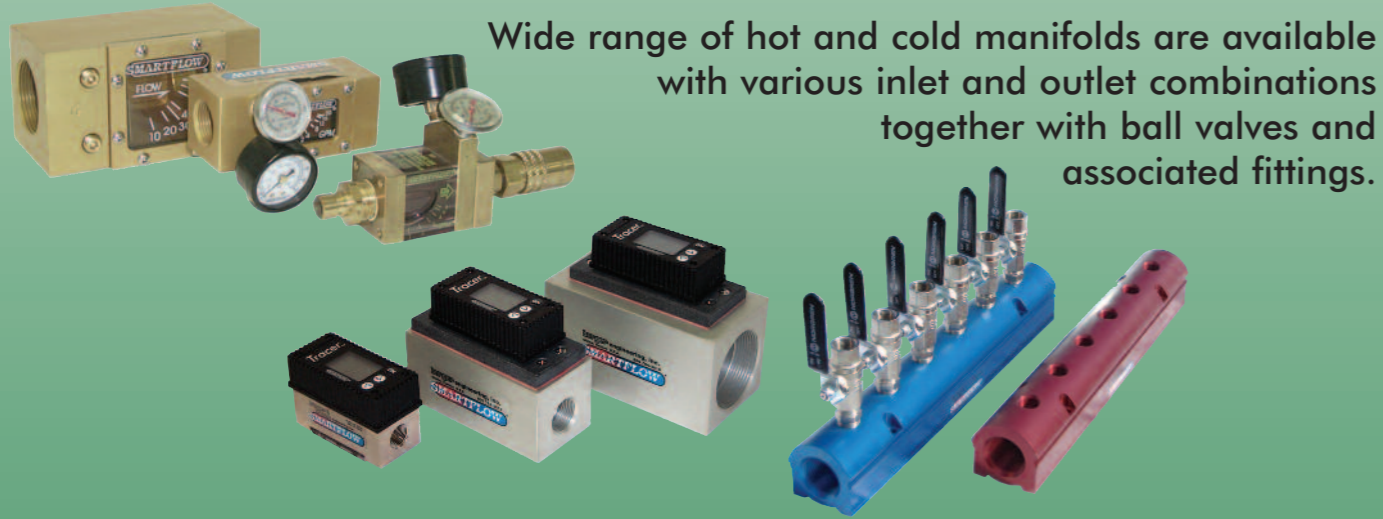

Wide range of hot and cold manifolds are available with various inlet and outlet combinations together with ball valves and associated fittings.

Mechanical flow meter devices are available to be installed as seen in picture or in individual lines to certain tool circuits, these show both pressure and flow. Range of sizes available all BSP threads.



Digital version of the flow meters are readily available with a visual display on the unit and the option to take data from the unit and link into moulding machine control if required. All inlet/outlet have standard BSP threads.



Renmar Limited · Unit 5 Sanders Close · Finedon Road Industrial Estate  
Wellingborough · Northamptonshire · NN8 4HQ

Tel: 0844 6933225 • Fax: 01933 270498

Email: [info@renmarltd.com](mailto:info@renmarltd.com) • Web: [www.renmarltd.com](http://www.renmarltd.com)

# RENMAR



AEC range of mould heater and chillers utilising latest technology and refrigerant.

Offering Full materials handling, drying and blending equipment from AEC



Cumberland shredders and granulators ranging from beside the press to central.



The AMUT range of thermoforming machines offer excellent value for money for all technical and packaging applications.

The AMUT extrusion lines offer standard and custom built solutions for all types of plastic production.



As part of Renmar's continued expansion within the ancillary market place we are extending our services to the users of any AEC or Virginio Nastri equipment with spare parts and after sales service work.

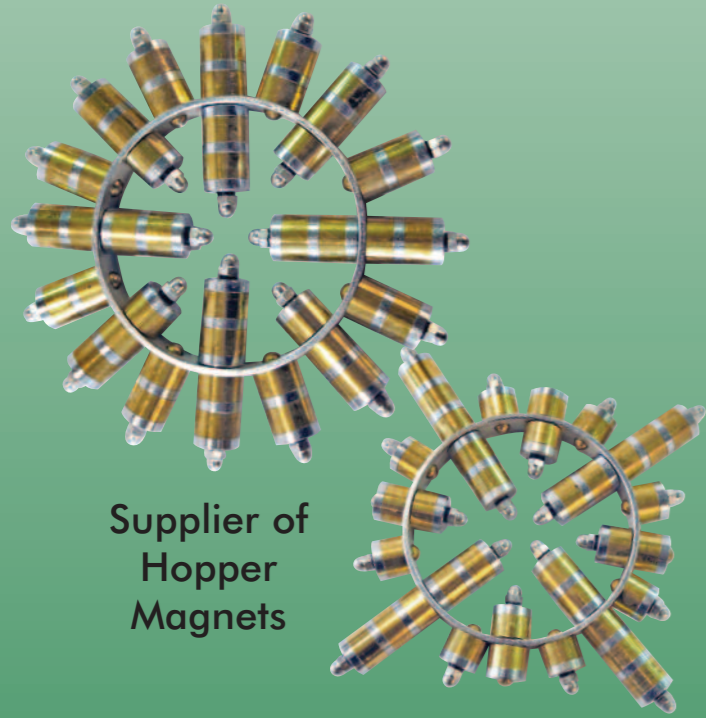

Supplier of Hopper Magnets

Supplier of Water Flow Regulators



Virginio Nastri range of conveyors and separators is very comprehensive with both standard and custom built options.

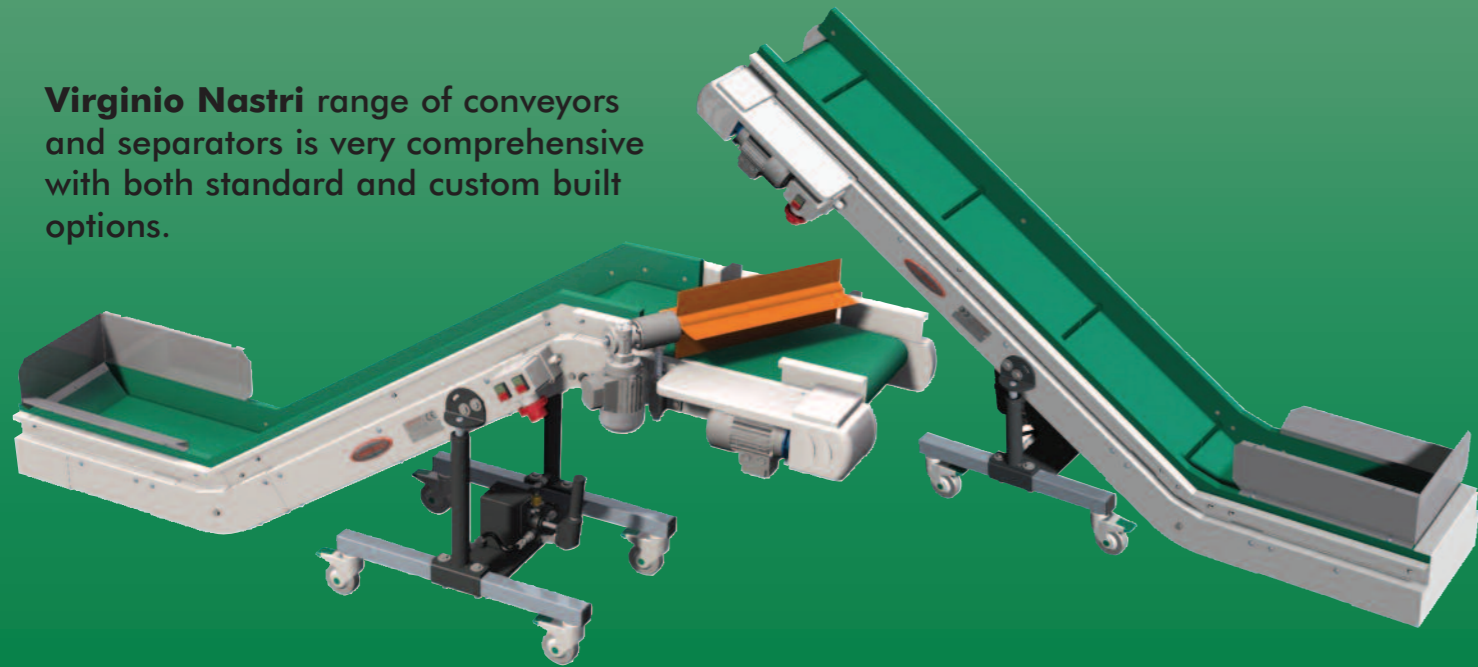

**Products Included:**

- AEC Whitlock - Materials Handling, Drying and Blending Equipment
- AEC/Sterlco - Water and Oil Temperature Control Units
- Cumberland - Granulators and Pelletisers
- Virginio Nastri - Belt Conveyors and Separators

We now provide new blades for any make and model of granulator



Full Granulator and Slitter Blade Refurbishment and Re-Sharping Service

