



Operation and Installation Manual

20 Series Granulators

Models 2025, 2035 and 2045

Important! Read Carefully Before Attempting to Install or Operate Equipment



Bulletin No. CG2-610

Write down your granulator _____
serial numbers here _____
for future reference. _____

Cumberland can advise you on proper selection and sizing of systems for your operating environment.

Cumberland is committed to a continuing program of product improvement. Specifications, appearance, and dimensions described in this manual are subject to change without notice.

Bulletin No. CG2-	DCN No. _____	Effective:
© Copyright Cumberland Engineering Corp. 2002		
All rights reserved.		

Cumberland Warranty Information

Thank you for your purchase of your new 20 Series Granulator. We are confident that you will have excellent results and trouble-free operation with this machine.

When the machine arrives at your plant, inspect it carefully for shipping damage before uncrating and immediately report any damage to your transportation company.

Customer Satisfaction Warranty Program for 20 Series Granulators:

The terms and conditions of the warranty set forth are for one (1) year from the original date of purchase by the original purchaser.

Cumberland Engineering warrants to the original purchaser the product and/or goods to which this disclaimer is attached, and manufactured by us, to be free from defects in material and workmanship under normal use and service. **THIS WARRANTY IS EXPRESSLY IN LIEU OF ALL OTHER WARRANTIES EXPRESSED OR IMPLIED, INCLUDING WARRANTIES OF MERCHANT ABILITY AND FITNESS FOR A PARTICULAR PURPOSE, AND ALL OTHER OBLIGATIONS AND LIABILITIES ON OUR PART.**

This warranty shall not apply to any goods or product manufactured by us which has been subject to accident, negligence, alteration of any kind, abuse, or misuse. We further make no warranty whatsoever in respect to accessories or parts not supplied by us. Any warranty of any nature shall apply only to an "original purchaser" which shall be deemed to mean that person or entity for whom the goods and/or product were originally ordered and installed.

We neither assume nor authorize any person to assume for us any liability in connection with the sale or use of the products and goods sold hereunder, and shall not be responsible for damages for which a purchaser may be liable to other persons, damages to property, or injuries to any other persons.

Our sole obligation under this warranty shall be limited to replacing, repairing, or exchanging any part or parts of goods and/or products sold which we determine are defective under normal use and service within one (1) year of date of installation by the original purchaser. We shall not be liable for any loss or damage resulting directly or indirectly from the use or loss of the goods and/or products purchased. In no event shall we be liable for any general, direct, consequential, incidental, or special damages of any kind.

We do not warrant any of our products that are installed in other machines or apparatus as meeting requirements of any safety code of any nature. The purchaser assumes all risks and liabilities resulting from the installation and use of product sold by us in combination with other machines or apparatus.

Cumberland Engineering Warranty Information

We warrant our product to be of the kind and quality quoted, and no other warranty except of title shall be implied. Our company shall repair or replace, at our discretion, any manufactured item on your 20 Series Granulator without charge FOB factory, within one (1) year after date of original purchase, which is proved to be defective when shipped. Claims for labour or consequential damages are not allowed.

Excluded from the above are knives, screens, and belts. Purchased items, including electrical components, motors, etc., shall carry the warranty of the supplier and no extension of that warranty is allowed.

Refer to this manual for assistance in installing and maintaining a highly efficient machine.

Table of Contents

1	Safety Considerations	9
1-1	Safety Guidelines	9
1-2	Safety Procedures	11
1-2-1	Guidelines for Moving the Granulator	11
1-2-2	Clearing a Jammed Cutting Chamber	11
1-3	Safety Features	12
1-3-1	Safety Features Fitted On the Granulator	12
1-3-2	Opening the Granulator	13
1-3-3	Sound Enclosure	Error! Bookmark not defined.
2	General Information	15
2-1	Introduction	15
2-2	Using This Manual	15
2-3	Safety Symbols Used in This Manual	16
2-4	Description	16
2-4-1	Technical Data	16
2-4-2	Main Components of Standard Granulators	17
2-4-3	Optional Equipment	17
3	Shipping Information	19
3-1	Unpacking and Inspection	19
3-2	In the Event of Shipping Damage	19
3-3	If the Shipment is Not Complete	19
3-4	If the Shipment is Not Correct	20
3-5	Returns	20
3-6	Uncrating Your Granulator	20
4	Installation	22
4-1	Lifting	22
4-2	Positioning the Granulator	22
4-3	Electrical Connection	23
4-4	Start-Up Checks	24
4-4-1	Checking the Cutting Chamber	24
4-4-2	Checking Rotation Direction	26
4-4-3	Test the Interlock Switches	27
4-4-4	Checking Knife Position	27

5	<i>Start Up and Operation</i>	29
5-1	Pre-Operational Checklist	29
5-2	Operation	30
6	<i>Maintenance</i>	31
6-1	General Recommendations	31
6-2	Monthly Maintenance Operations	32
6-2-1	Drive Belt Tension	32
6-2-2	Proper Belt Tension	32
6-2-3	Belt Replacement	33
6-3	Removal and Replacement of the Screen	33
6-4	Inspection and Adjustment of Knives	34
6-5	Removing and Replacing Bed Knives	36
6-6	Removal and Replacement of Rotating Blades	38
6-7	Specifications for Resharpener Bed Knives	39
6-8	Specifications for Resharpener Rotor Knives	40
7	<i>Troubleshooting</i>	41
7-1	General Problems	41
7-2	Electrical Problems	43
8	<i>Spare Parts</i>	44
8-1	Table 1: Recommended Spare Parts List	44
9	<i>Typical Wiring Diagram</i>	49
10	<i>Contact Information</i>	50

Table of Figures

<i>1. <u>Safety Switch</u></i>	<i>13</i>
<i>2. <u>Control Panel</u></i>	<i>14</i>
<i>3. <u>Noise Test Specifications</u></i>	<i>Error! Bookmark not defined.</i>
<i>4. <u>Average Sound Levels</u></i>	<i>Error! Bookmark not defined.</i>
<i>5. <u>Noise Test Method</u></i>	<i>Error! Bookmark not defined.</i>
<i>6. <u>Main Components of Standard Granulators</u></i>	<i>17</i>
<i>7. <u>Overall Dimensions and Weights</u></i>	<i>18</i>
<i>8. <u>Lifting the Granulator</u></i>	<i>21</i>
<i>9. <u>Inserting the Bin</u></i>	<i>23</i>
<i>10. <u>Electrical Connections</u></i>	<i>24</i>
<i>11. <u>Removing the Screw Knob</u></i>	<i>26</i>
<i>12. <u>Checking the Knife Gap</u></i>	<i>28</i>
<i>13. <u>Periodic Maintenance Table</u></i>	<i>32</i>
<i>14. <u>Belt Tension Chart</u></i>	<i>34</i>

15.	<u>Removing The Screen</u>	35
16.	<u>Inspection of Knives</u>	37
17.	<u>Bed Knife Specifications</u>	40
18.	<u>Rotor Knife Specifications</u>	40
19.	<u>Cutting Chamber - Vertical Cross Section</u>	45
20.	<u>Cutting Chamber - Longitudal Cross Section</u>	46
21.	<u>Cutting Chamber - Front View</u>	47
22.	<u>Cutting Chamber - Rear View</u>	48

1-1 Safety Guidelines

Our granulators are designed to provide safe and reliable operation when installed and operated within design specifications, following national and local safety codes.

To avoid possible personal injury or equipment damage when installing, operating, or maintaining this granulator, use good judgment and follow these safe practices:

- LEARN AND OBEY** your company's safety policy regarding granulating equipment.
- MOVING OR LIFTING THE GRANULATOR:** Although our equipment is built and engineered for great ruggedness in operation, care must be taken when moving the machine along the floor or lifting it. Damage may occur to sheet metal covers, electrical cabinets, or small brackets if pressure is applied to them when moving the granulator. When lifting the granulator, be certain of total machine weight and the capability of the lifting equipment. (See the Granulator Specification Sheets for machine weights and dimensions.)
- GRANULATOR LOCATION:** Adequate area for routine maintenance should be provided in order to open the machine for knife, screen, or cleanout service. Proper service area clearances also should allow people who are working on the machine to be clearly visible to others, thereby reducing the potential safety hazards.
- SAFE HOUSEKEEPING:** The work area must be kept clean and uncluttered during periods of operation or maintenance. No hand tools or other metal objects should be left on or around the machine. Any tools or other metal objects which mistakenly fall into the hopper feed opening can cause severe damage to internal cutting chamber and screen chamber components.
- SAFETY GLASSES OR A FACE SHIELD MUST ALWAYS BE WORN** when servicing or operating the machine. Although our machines are designed for the maximum in flyback control, caution must be used when operating near the hopper feed opening in order to guard against unexpected material flyback.

- EAR PROTECTION** may be required when operating the machine during granulation of very hard or noisy materials.

- NEVER** attempt to operate the granulator unless it is fully assembled with all guards and interlocks in place and functional.
- OBSERVE** all danger, warning, caution and safety labels on the equipment.
- Upon completion of any machine maintenance, be certain **ALL SAFETY GUARDS AND COVERS** are securely and properly fastened prior to resuming machine operation. All fasteners must be in place and properly tightened. **ANY SHORTCUTS MAY RESULT IN INJURY TO PERSONNEL OR DAMAGE TO EQUIPMENT.**
- NEVER** wear any loose fitting clothes, neckties, or dangling items such as earrings, belts, or shoestrings. Jewelry, such as wristwatches, bracelets, or rings should **NEVER** be worn. Long hair must be tied back or placed in a tight fitting hairnet. **NEVER** lean against or rest hands or feet on the granulator when it is in operation or open for maintenance. **NEVER** stand on the granulator when it is in operation.
- ROTATION OF MOTORS:** All rotating items in the granulator are clearly marked on the machine. Always check for proper rotation of motors.
- ELECTRICAL GROUNDING:** All electrical equipment on the granulator must be grounded in accordance to all local codes.
- ALWAYS DISCONNECT AND LOCKOUT** the main electrical power to the granulator before performing any service.
- SAFETY INTERLOCKS MUST NOT BE BYPASSED.** The mechanical and electrical safety interlocks ensure the safety of personnel. They should never be tampered with or removed for **ANY** reason. They should be checked frequently by a qualified mechanic for proper operation.
- NEVER** modify the machine configuration or any individual component without written consent from Cumberland.

Cumberland has long recognized the importance of safety and has designed and manufactured its equipment with operator safety as a prime consideration. We expect you, as a user, to abide by the foregoing recommendations in order to make operator safety a reality.

SAFETY IS NO ACCIDENT

1-2 Safety Procedures

1-2-1 Guidelines for Moving the Granulator

To lift and move the granulator safely and correctly, cover any sharp corners or edges, and use the type of equipment that has the most appropriate features and capacity.

Before lifting, check that there are no items that could fall during lifting.

Before positioning the granulator, check that the floor is level and is strong enough to support the load, that there is adequate space in the installation area to allow the movement of equipment necessary to the task and to enable any necessary maintenance work to be carried out unhindered.

1-2-2 Clearing a Jammed Cutting Chamber

1. Disconnect and lockout power.
2. Be certain that the rotor is motionless.
3. Open the front panel and remove the bin.
4. Unscrew the screw knob, which keeps the hopper and screen cradle in place.
5. Remove the screen.

!! CAUTION !!

NEVER ATTEMPT TO FREE A JAMMED MACHINE BY PLACING HANDS ON ROTOR, ROTOR KNIVES, OR WITHIN THE CUTTING CHAMBER.

HANDS MUST BE KEPT CLEAR OF THE ROTATIONAL PATH OF THE ROTOR KNIVES.

A block of wood should be used to exert force on the rotor, usually in the direction opposite normal rotation.

Good footing on a clean floor is essential and the body should be well braced when performing this act. Guard against loss of balance should the jammed conditions suddenly come free.

A leather mallet and block of wood of sufficient length to keep hands away from the path of knives can be used if required.

Use pliers in removing material from the cutting chamber, keeping in mind that the removal of material may cause rotation of the rotor and rotor knives.

After clearing the jam, be certain that the hopper screen, and all guards and covers are secured in place before connecting power and starting the machine.

1-3 Safety Features

The granulators are equipped with safety features intended to protect personnel and the granulator. Do NOT remove or tamper with such equipment.

1-3-1 Safety Features Fitted On the Granulator

All moving drive parts, including the two pulleys and the belt, are contained in a guard, which may only be removed using specific tools and moreover cannot be fixed in the correct position without special fastenings.

Warning!

Always make sure that the guard is in position before starting the granulator.

The upper part of the cutting chamber is protected by the feed hopper, used to insert material to be granulated while the lower part is protected by the screen, and screen support. These components are fixed by a screw knob, unscrewing releases a safety switch key (Figure 1), which cuts off the electric supply to the motor, causing the rotor to stop.

The method of opening the granulator has been designed to restrict operator access, allowing the rotor and all moving knives to stop completely. To allow operator access more quickly could be dangerous as it might be possible to make contact with the granulator knives while they are still rotating.

Figure 1: Safety Switch



1-3-2 Opening the Granulator

The Start/Stop lighted pushbutton provided on the control panel (Figure 2) is used to operate the granulator. The button must be pressed to stop the granulator and pulled out to start.

Before performing any maintenance or opening the granulator, perform the following procedure:

1. Turn off the granulator using the pushbutton provided.
2. Turn the disconnect switch to OFF and lockout power. (If you cannot lock out power, remove the power fuses in the control panel.)
3. Tag the machine as Out of Service.
4. Make sure the rotor has come to a complete stop.

Warning!

Wear protective gloves when exposed to knives.

Figure 2: Control Panel



2-1 Introduction

This family of granulators has been designed to granulate plastic material such as sprues, runners, and small reject parts.

The granulator is comprised of an infeed hopper into which the material to be granulated is fed, mounted on a cutting chamber in which a series of rotary and bed knives reduce the material to granules, the size of which is determined by the screen holes. The granules fall and collect in the bin below. The operation of the granulator is controlled by a control panel and powered by an electric motor.

2-2 Using This Manual

Use this manual as a guide and reference for installing, operating, and maintaining your granulator. The purpose is to assist you in applying efficient, proven techniques that enhance equipment productivity.

The General Information section outlines models covered, standard features, and available options. Additional sections within the manual provide instructions for installation, pre-operational procedures, operation, preventive maintenance, and corrective maintenance.

Installation instructions include all required data for receiving, unpacking, inspecting, and setup of the granulator. Whenever possible, illustrations have been included to help you complete these tasks more efficiently. We can also provide the assistance of a factory-trained technician to help train your operator(s) for a nominal charge.

Pre-operational procedures include instructions, checks, and adjustments that should be followed before commencing with operation of the granulator. These instructions are intended to supplement standard shop procedures performed at shift, daily, and weekly intervals.

The Operation chapter includes a description of electrical and mechanical controls, in addition to information for operating the granulator safely and efficiently.

The Maintenance chapter is intended to serve as a source of detailed assembly and disassembly instructions for those areas of the equipment requiring service. Preventive maintenance sections are included to ensure that your granulator provides excellent, long service.

The Troubleshooting chapter serves as a guide for identification of most common problems. Potential problems are listed, along with possible causes and related solutions.

The Spare Parts section contains a list of parts that may require replacement. A spare parts list with part numbers specific to your machine is provided with your shipping paperwork package. Refer to this section for a listing of spare parts for purchase. Have your serial number and model number ready when ordering.

2-3 Safety Symbols Used in This Manual

The following safety alert symbols are used to alert you to potential personal injury hazards. Obey all safety messages that follow these symbols to avoid possible injury or death.

DANGER indicates an *imminently* hazardous situation, which, if not avoided, *will* result in death or serious injury.

WARNING indicates a *potentially hazardous* situation or practice which, if not avoided, *could* result in death or serious injury.

CAUTION indicates a potentially hazardous situation or practice which, if not avoided, *may* result in minor or moderate injury, or in property damage.

2-4 Description

2-4-1 Technical Data

Infeed:	Front or top entry
Infeed hopper:	For manual feeding
Cutting Chamber:	Upright bolted type
Rotor:	3 knife rotor w/lateral disks
Cutting System:	Scissor action with double angle cutting
Knives:	Tool steel

2-4-2 Main Components of Standard Granulators

(See Figure 3)

1. Infeed hopper
2. Cutting chamber
3. Bin for granulated material
4. Belt drive
5. Control panel
6. Electric Motor

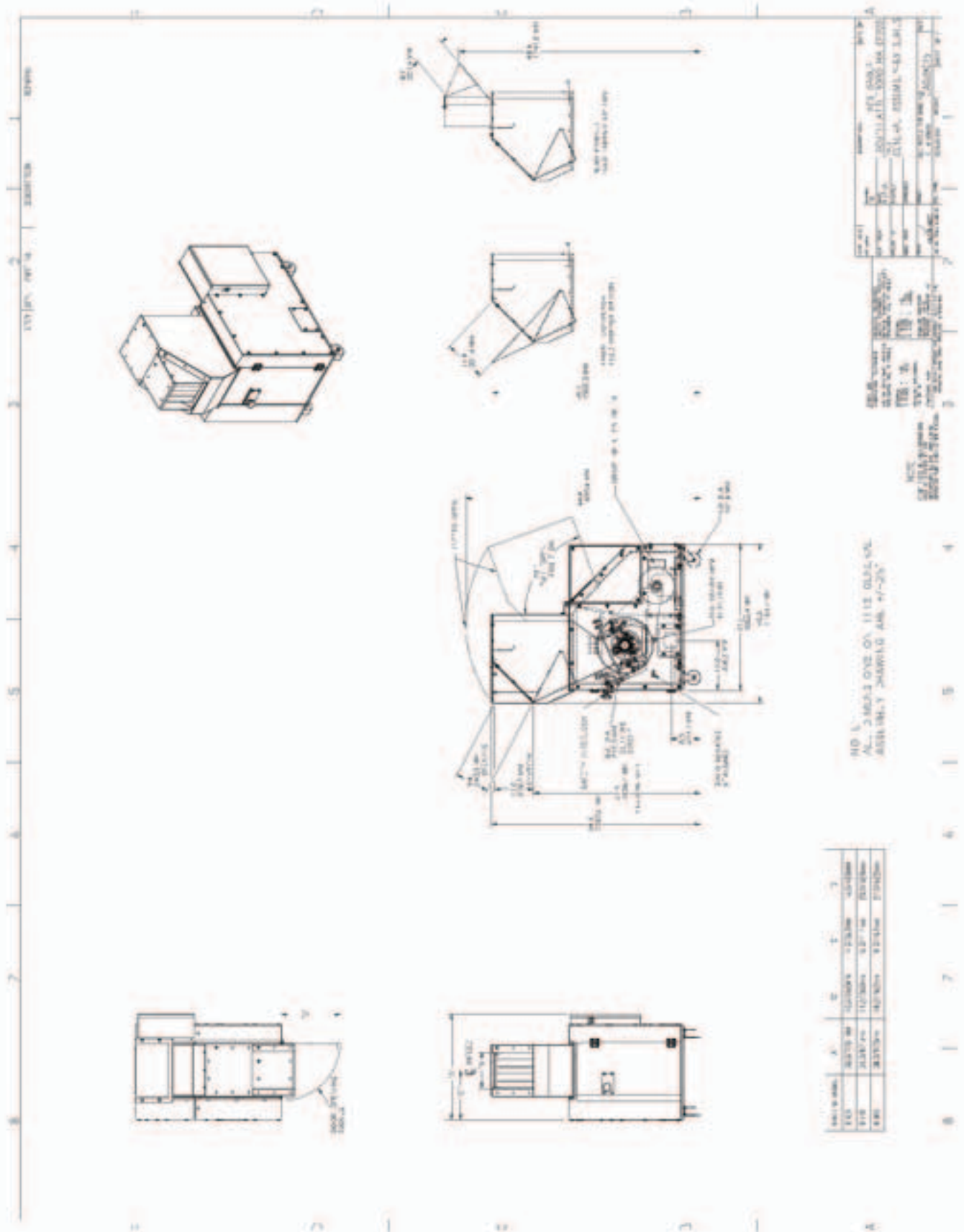

Figure 3: Main Components of Standard Granulators

2-4-3 Optional Equipment

- Conveyor
- Other screen hole sizes
- Blower/airveying system
- Vacuum bin
- Special operating voltages

Figure 7: Overall Dimensions Weights – SEE BELOW DWG CA039015 FOR GEOMETRY & TABLE



3

Shipping Information

3-1 Unpacking and Inspection

You should inspect your granulator for possible shipping damage.

Thoroughly check the equipment for any damage that might have occurred in transit, such as broken or loose wiring and components, loose hardware and mounting screws, etc.

3-2 In the Event of Shipping Damage

Important!

According to the contract terms and conditions of the Carrier, the responsibility of the Shipper ends at the time and place of shipment.

Notify the transportation company's local agent if you discover damage

Hold the damaged goods and packing material for the examining agent's inspection. **Do not return any goods before the transportation company's inspection and authorization.**

File a claim with the transportation company. Substantiate the claim by referring to the agent's report. A certified copy of our invoice is available upon request. The original Bill of Lading is attached to our original invoice. If the shipment was prepaid, write us for a receipted transportation bill.

Advise the shipping department regarding your wish for assistance and to obtain an RMA (return material authorization) number.

3-3 If the Shipment is Not Complete

Check the packing list as back-ordered items are noted on the packing list. You should have:

- Granulator
- Bill of lading
- Packing list

- Operating and Installation packet
- Detailed recommended spare parts list
- Electrical schematic and panel layout drawings
- Component instruction manuals

Re-inspect the container and packing material to see if you missed any smaller items during unpacking.

3-4 If the Shipment is Not Correct

If the shipment is not what you ordered, **contact the shipping department immediately**. For shipments in the UK and Europe, call +44 (0) 1453768980; for all other countries, call our international desk at (508) 399-6400. Have the order number and item number available.

Hold the items until you receive shipping instructions.

3-5 Returns

Important!

Do not return any damaged or incorrect items until you receive shipping instructions from the shipping department.

3-6 Uncrating Your Granulator

Prepare in advance the site you have selected for installation of the granulator. Be certain that the area to be occupied by the machine is clean, level, and free of obstructions. The site you have selected must have a floor rating to adequately support the weight of the machine.

Your granulator is mounted on a wooden skid and blocked and banded to secure it for shipment. All non-painted items subject to corrosion are coated with a quality rust preventative, and the machine is covered with heavy-duty polyethylene to protect it from moisture and dirt. Granulators are normally shipped completely assembled unless the size of the machine or an agreement for special shipping arrangements prompts partial assembly.

If inspection, after shipment, has revealed no shipping damage, unpack the unit by removing the polyethylene protective covering and banding. Remove the envelope with the parts list, assembly

drawings, electrical schematics, and manual from the base evacuation area.

You can now have the machine lifted from the skid. A forklift is ideal for the purpose, but take care to **properly position the forks** between the casters and the centrally mounted evacuation pipe from the side of the machine. (See Figure 5)

Figure 5: Lifting the Granulator



! CAUTION !

Do not attempt to lift the granulator by means of any shaft or protruding member, ESPECIALLY THE HOPPER

4-1 Lifting

Important!

Before lifting or moving the granulator, check the relative weight shown on the shipping papers and in Figure 4.

To facilitate the lifting operation using forklift trucks, the drop box has been removed from the granulator and is packed with any spare parts.

When using a forklift to move the granulator, make sure it is suitable for the weight and dimensions of the granulator. When moving, take care not to damage delicate parts. To lift the machine with a forklift, place the carriage forks under its base (See Figure 5). Where a forklift truck is not available, it is possible to use cables or belts, provided that they are strong enough to support the weight of the granulator, then carry out the lifting procedure.

Important!

During the movement, the load must remain in a horizontal position, regardless of the type of equipment used.

4-2 Positioning the Granulator

Important!

Make sure that the base on which the granulator is supported is solid and completely level, in order to rigidly support the granulator without its being subjected to vibration. It is recommended that the floor be reinforced concrete with a very smooth support surface.

Place the granulator in an area large enough to allow sufficient space on all sides for the operator to carry out maintenance.

Although the granulator controls and electrical components comply with CE codes and regulations, the machine must be placed in an area free from humidity, dampness, and

water. The granulator should be installed in an inside covered, weather-proof environment and away from any areas where water collects on the floor.

Once the granulator is in position, the front panel must be opened in order to insert the bin as



illustrated in

Figure 6.



Figure 6: Inserting the Bin

4-3 Electrical Connection

It is extremely important that the machine is correctly wired into the plant power source by a licensed electrician. See Section 9 for a wiring diagram.

All electrical equipment must be properly grounded in accordance with local and national codes to protect personnel from electrical shock. A fusible, lockable disconnect between the plant power source and the machine electrical cabinet is highly recommended.

!!Caution!!

Before connecting the power, check that the power cable size and capacity corresponds to the horsepower and amp load indicated on the granulator label and that the disconnect switch is in the OFF position. (See Figure 2.)

Unless otherwise specified, the granulator has been wired for 400 volts, 50 Hz, 3 ph.

The power cable from the plant source can be run directly to the control panel or through the base of the machinery. To run the power cable through the base of the granulator, perform the following steps:

1. Open the back cover, and insert the power cable from underneath the granulator.
2. Pass the power cable through the appropriate hole, and insert it into the control panel through a connector placed at the base.
3. Connect the three phase wires to the appropriate terminals of the main switch, and connect the ground wire to the terminal provided near the main disconnect switch. (See Figure 7.)

Figure 7: Electrical Connections

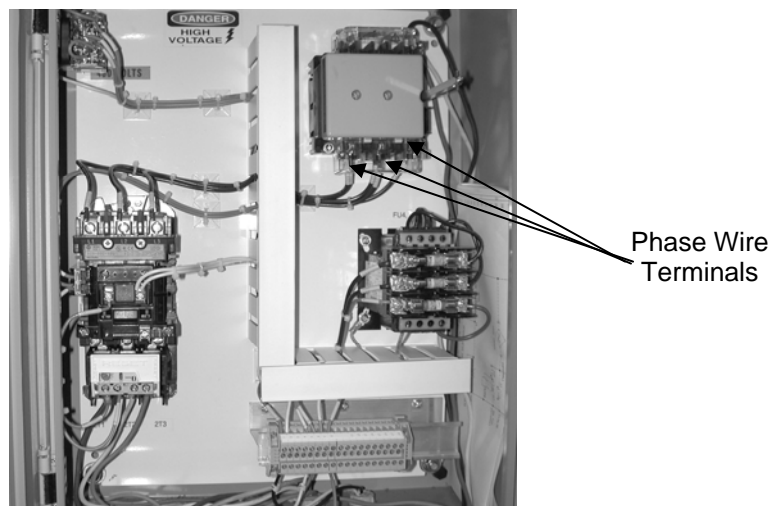

4-4 Start-Up Checks

4-4-1 Checking the Cutting Chamber

Before starting the granulator, open the cutting chamber to ensure that during transportation or installation, no foreign objects have

fallen in. The use of heavy gloves is recommended to avoid injury when exposed to the knives in the cutting chamber.

NOTE: This operation must be carried out by an operator / mechanical maintenance engineer.

Check that the cutting chamber is free from foreign objects as follows:

1. Turn off and lockout the machine power to the granulator or remove the fuses from the main control panel.
2. Open the front panel, and remove the bin.

Unscrew the screw **knob**, and carefully lower the screen. (See



3. Figure 8.)
4. Pivot back the feed hopper to gain free access to the cutting chamber.
5. Check that there are no foreign objects in the cutting chamber.
6. Check to be sure the bed knife and rotor knife bolts are at the proper torque and the knife gap is set according to specifications. See Sections 4-4-4 and 6-4.
7. After completing the checks, close the hopper and screen, and fasten them with the corresponding **knob**; reinsert the bin. Then close both the rear cover and the front panel.
8. Remove the drive belt guard by unscrewing the ten fastening screws.
9. Manually give the rotor at least one complete turn using the rotor pulley.
10. If there are no warning noises or signs of friction, this means the cutting chamber is completely clear. Replace the belt guard, remove lockout devices, and turn power on.



Figure 8: Removing the Screw Knob

4-4-2 Checking Rotation Direction

Check the correct direction of the rotor as follows:

1. Turn the main disconnect switch to “ON”.
2. Pull the Start button until the motor comes up to speed; then push the button to stop the granulator motor.
3. Check via the appropriate window that the rotor direction corresponds to that shown on the arrow label that is located above the guard.

If the rotation direction is correct, the granulator is ready to use. If the rotation direction is incorrect, reverse the rotor direction as follows:

!!Warning!!

A LICENSED ELECTRICIAN must carry out this operation.

1. Disconnect and lockout the power to the machine at the incoming power source. If the disconnect is not lockable, remove the fuses.
2. Reverse any two of the three power line conductors to the machine. If there is more than one motor on the machine and only one is turning in the wrong direction, reverse any two of the three line conductors at the overload relay for that motor.
3. Unlock the power and switch the electrical disconnect switch to “ON”. (Replace the fuses if necessary.)
4. Re-check the rotation direction of the motors.

4-4-3 Test the Interlock Switch

With the cutting chamber and screen cradle closed and power On, perform the following tests:

1. Push the start button to start the granulator.
2. **With the granulator running, loosen the handknob on the front access door to verify the safety interlock switch shuts the machine off. If the hand knob is completely loose and the power does not disconnect, the interlock switch is not working and the cause of the malfunction must be determined.**
3. **Turn off the power and lockout the power.**
4. Have the electrician check the interlock switch on the hopper to correct the malfunction.
5. If necessary, engage the screen cradle interlock actuator screw.

Having completed the above procedures, close the control panel. Unlock power or return the fuses in the supply panel, turning the disconnect switch to “ON”. Pull the start button and release only when the motor has started, then check again that the rotor is turning in the correct direction.

4-4-4 Checking Knife Position

NOTE: This operation must be carried out by an operator / mechanical maintenance engineer.

Before undertaking any type of work on the machine, use a feeler gauge to check the distance between the bed knives and the rotor knives (the knife gap).

To access the cutting chamber, follow the same procedure and observe the precautionary steps given in Section 4-4-1. Before proceeding to the checks, it is advisable to block the rotor to avoid any inadvertent rotation.

Once you have safely accessed the cutting chamber, check the current distance between the bed knives and the rotor knives using a feeler gauge. (See



Figure 9.)

NOTE: The distance set by the manufacturer for normal application is 0.006”-0.008” (0.15-0.20 mm). If the gap between the bed knives and the rotor knives is found to be greater than that, an adjustment must be made. (See Section 6-4: Inspection and Adjustment of Knives.)

Once you have checked the knife gap, close the hopper, secure it with the appropriate swing **bolt**, reinsert the bin, and close the front panel.



Figure 9: Checking the Knife Gap

5-1 Pre-Operational Checklist

To ensure the granulator is ready for operation, perform the tasks listed on the following pre-operational checklist. Make sure that all electrical and mechanical machine elements are inspected and any defects corrected first.

- Have all installation and preparation instructions been read and followed?
- Have the granulator operators and all other necessary personnel, such as the cleanout, maintenance and service persons, been fully trained on machine operation and all machine safety mechanisms?
- Have the granulator operator and all other necessary personnel, such as the cleanout, maintenance and service persons, read the Operation and Installation Manual?
- Have sufficient location clearances been allowed?
- Has the equipment been grounded as required by local codes

- Have all motors been checked for proper rotation?
- Have all machine controls, pushbuttons, and limit switch interlocks been checked for proper functioning?
- Has the cutting chamber been checked for foreign matter?
- Have the drive components been checked for alignment and tension?
- Is the machine properly closed with all visible fasteners tight?
- Are all accessory components electrically and mechanically connected with proper support and with all fasteners tight?
- Are all electrical enclosure boxes tightly closed and clamped shut?
- Are all personnel clear of the machine?

5-2 Operation

The granulator can be operated in a vertical top feed position or in a horizontal front feed position.

Before starting the granulator, always check for and remove tools or any other objects placed on the granulator. Turn the Power disconnect switch to “ON”, pull the Start button, and release it when the motor has started.

It is quite normal for the motor not to start immediately, as the electronic system must check all the micro switches before enabling start up procedures. Wait for the electric motor to reach normal rotating speed before feeding the granulator.

!!Warning!!

Never push material into the hopper with hands.

If the hopper becomes blocked, the granulator must be turned off, and the power must be locked out or the fuses removed.

Before stopping the granulator for the end of a working shift or for any other reason, stop feeding in the material to be granulated, and leave the granulator running for several minutes to allow the cutting chamber to completely granulate and empty the material inside. Press the lighted Start/Stop button, which will immediately turn off the granulator.

Important!

If the granulator stalls frequently during use, it may be necessary to adjust the calibration of the “overload.” (Refer to the values shown in the electrical diagram.)

6-1 General Recommendations

Before carrying out any work on the granulator, carefully read the instructions contained in this manual.

NOTE: Only specialist and competent personnel should carry out this operation.

All maintenance work must be carried out with the granulator switched off and with the power supply disconnected and locked out.

Conduct that is not in accordance with the safety instructions in Section 1 may pose a threat to both personnel and equipment.

Instructions given in the maintenance procedures should be strictly followed.

Once the maintenance work is completed, before returning the granulator to service, check the following:

- Any parts that may have been replaced and/or tools that have been used are removed from the granulator.
- All safety equipment is in proper working condition.

Figure 10: Periodic Maintenance Table

Mechanical Check	Frequency
Knife clearance and wear	Weekly
Rotor knife retaining screws for tightness	Weekly
Downstroke bed knife and shield retaining screws for tightness	Weekly
Upstroke bed knife retaining screws for tightness	Weekly
Screen cradle arm screws for tightness	Weekly
Infeed chute & cutting chamber screws for tightness	Monthly

Important!

**After the granulator has been used for the first day, adjust the drive belt tension.
Correct tension for use should be the minimum at which the belt does not slip.
Check that the pulleys are correctly aligned.**

6-2 Monthly Maintenance Operations

6-2-1 Drive Belt Tension

NOTE: This operation should be carried out by an operator / mechanical maintenance engineer.

For the granulator to function correctly, it is extremely important that the drive belt is always tight. Correct tension reduces the load of the rotor bearings and minimizes wear and stretching of the belt. To check and adjust belt tension, carry out the following procedure:

1. Turn off the machine and lockout power by using the disconnect switch, or remove the fuses from the electrical control panel.
2. Remove the belt guard by unscrewing the ten screws that hold it in place.
3. Open the front panel.
4. Remove the bin.
5. Open the rear panel.
6. Loosen the nuts that lock the motor base slide.
7. Loosen the tie rod
8. Adjust the belt tension, turning the tie rods forward.
9. Turn the tie rod to bring the motor square to the belt axis.
10. After the adjustment, lock the nuts again, and close the rear panel, refitting the proper locking latch.
11. Reinsert the bin, close the front panel, refit the belt guard and unlock the power or replace the fuses in the control panel.

6-2-2 Proper Belt Tension

Measure the belt span and divide by 64 to get the allowable belt deflection. With a belt gauge, measure the force it takes to deflect the belt the amount calculated.

NOTE: Check your belt gauge's instructions for proper scale settings. Belt tension gauges are available from customer service or your belt manufacturer.

Compare the gauge reading with the chart value for the belt cross-section used. (See

Figure 11: Belt Tension Chart

Belt Cross Section	Small O.D. Range	*Deflection Force Lbs/V-belt	
		Run-In	Normal Running
3VX	3.65-4.12	6.4	5.7-4.4
	4.50-5.60	7.5	6.6-5.1

$$\text{Deflection} = \frac{\text{Beltspan}}{64}$$

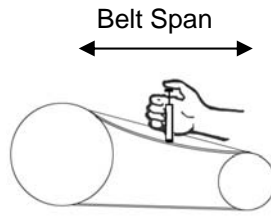

Belt Deflection Guage

6-2-3 Belt Replacement

Important!

It is very important to replace all belts at the same time.

If the drive belts have to be replaced, follow the procedure in Section 6-2-1 up to Step 6. Then release the belt from tension by fully unscrewing the tie rods. Slip off the belts, and replace them with new ones. Continue with the procedure for adjusting the belt tension.

6-3 Removal and Replacement of the Screen

NOTE: A qualified operator/maintenance mechanic should carry out this procedure.

1. Switch the machine off and lockout power by turning the disconnect switch to “OFF”, or remove the fuses from the main control pane.
2. Open the front panel.

* The Deflection Force Value shown is for each belt and must be multiplied by the number of V-belt elements if all are deflected.

3. Remove the bin.
4. Remove the screw knob that holds the hopper on top of the cutting chamber. Carefully lower the screen cradle assembly, resting it on the base.

Remove the screen, keeping it in a horizontal position. (See



5. Figure 12.)
6. Replace the screen with a new one, tighten the screw knob, reposition the bin, and close the front panel. Unlock the power and turn the machine back on.



Figure 12: Removing the Screen

6-4 Inspection and Adjustment of Knives

NOTE: This operation must be performed by a qualified operator / mechanical maintenance technician.

Important!

Before carrying out any maintenance on the cutting chamber, the operator must wear work gloves thick enough to avoid injury to the hands while touching sharp parts or the cutting edges of the blades.

To inspect blades, remove the screen by following steps 1-0 in Section 6-3. Then, proceed as follows:

1. Open the rear-closing panel by releasing the locking latch.
2. Pivot the in-feed hopper completely back to gain clear access to the cutting chamber, and clear any process material or foreign objects between the knives.
3. Turn the rotor slowly until the first row of rotor knives are in close proximity to the bed knife cutting edge. Turn the rotor backwards, keeping hands and fingers from directly contacting sharp knife-edges.
4. Using a feeler gauge, measure the gap between the rotor and knife cutting edges. Check each rotor knife to find the “high knife” or the knife that measures the smallest gap. If the gap is substantially greater than the specified 0.006” - 0.008” (0.15 mm – 0.2 mm), the knives need readjustment.
5. Loosen the bed knife shield hold down screws and remove the shield. (See **Error! Reference source not found.**)
6. Leave the screws that hold the bed knife just tight enough to allow the bed knife to move.
7. Loosen the adjustment screws and lock nuts. (See **Error! Reference source not found.**)
8. Insert a 0.006” – 0.008” (0.15 mm – 0.2 mm) thickness gauge between the cutting edge of the bed knife and that of the high rotor knife.
9. Adjust the bed knife into the rotor knife using the adjustment screws, so as to leave enough space for the thickness gauge to move.

NOTE: Check that the distance between the fixed and rotating knife is the same at both ends of each knife. Move the bed knife using the push adjusting screws a little at a time on each end.

10. When adjustment is complete, tighten the lock nuts on the adjustment screws.
11. Torque the bed knife **and bed knife shield** bolts to 95 lbs./ft. (13 Kgm., 128 Nm) using a torque wrench.
12. Repeat the steps 4-11 to adjust the rear (or down stroke) bed knife. Turn the rotor slowly for one complete revolution, checking the exact distance between all the rotary knives and the bed knives.
13. Close the hopper and replace the screen and screen cradle, securing them in place using the swing **bolt** provided.
14. Close the front and rear doors, and unlock the power or replace the fuses in the control panel. Turn the disconnect switch to "ON".

Figure 13: Inspection of Knives

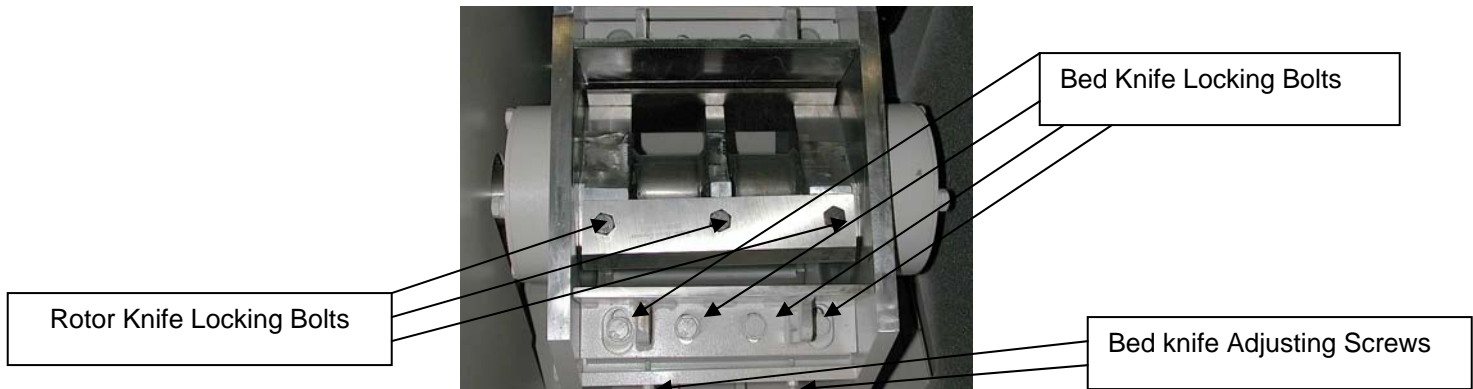

6-5 Removing and Replacing Bed Knives

NOTE: This procedure should be performed by a qualified operator / maintenance mechanic. Protective gloves must be worn to avoid injury when handling the cutting knives.

To remove and replace bed knives, complete the following procedure:

1. Open the granulator by following Steps 1-0 in Section 6-3.
2. Open the rear-closing panel by releasing the locking latch.

3. Pivot the in-feed hopper completely back to gain clear access to the cutting chamber, and clear any process material or foreign objects from between the knives.
4. Rotate the rotor so that the rotor knives will not interfere with the removal of the bed knife. Using a wooden block, block the rotor to prevent it from rotating while removing the knives.
5. Loosen the lock nuts and back off the adjustment screws. (See **Error! Reference source not found.**)
6. Loosen and remove the bed knife shield bolts and remove the shield, positioned above the knife. **The remaining bed knife bolts and bed knife may now be removed.**
7. Perform the above steps to remove the rear (upstroke) bed knife as well.

NOTE: Before replacing the bed knife with new or sharpened knives, wipe the knife seats on the knife block, being sure to clean off all process material. The tapped holes in the knife block (used for holding the knives in place) should be clear of any dirt, oil, or process material.

8. Install new or sharpened bed knives on each knife seat, making sure that the rotor is blocked to prevent it from rotating while installing each knife. Be sure to place the bed knives in the correct positions—the rear (up stroke) bed knife must be placed with the extended cutting edge on the bottom, and the front (down stroke) bed knife should be placed with the cutting edge on the top.
9. **Before re-installing the knife bolts, wipe them clean with a lightly oil-damped cloth. Do not leave an oil film on the bolt since lubrication can adversely affect the stress on the bolt when torqued to the specified values. It is recommended that the knife bolts be replaced with each new set of knives. This will reduce the risk of bolt failure due to overstretching. Always use the specified replacement bolts.**
10. **Tighten the bolts that hold just the bed knife, enough to keep the knife in place, while still allowing the adjusting screws to move the knife forward.**
11. **Adjust the knife gaps with the rotor knives, following Steps 8-12 in Section 6-4.**
12. **Replace the shields in position above the bed knives. The shield on the front (down stroke) bed knife should be positioned so that the inside edge is set back approximately 1/32” from the cutting edge below it. Replace the remaining bolts and torque.**

13. Close the machine, following Steps 12-14 in Section 6-4.

6-6 Removal and Replacement of Rotating Blades

NOTE: A qualified operator / maintenance mechanic should perform this operation. Protective gloves must be worn to avoid injury when handling the cutting knives.

To remove and replace rotor knives, complete the following procedure:

1. Open the granulator by following Steps 1-0 in Section 6-3.
2. Open the rear-closing panel by releasing the locking latch.
3. Pivot the in-feed hopper completely back to gain clear access to the cutting chamber, and clear any process material or foreign objects from between the knives.
4. Rotate the rotor so that the knife bolts are in a convenient position to remove the bolts with the appropriate wrench. Using a wooden block, block the rotor to prevent it from rotating while removing knives or after a knife has been removed.
5. Loosen and remove the knife bolts and lift the knife off the knife seat removing it from the cutting chamber.
6. Perform the above steps until all the rotor knives are removed.

NOTE: Before replacing the rotor knife with new or sharpened knives, wipe the knife seats on the rotor, being sure to clean off all process material. The tapped holes in the rotor (used for holding the knives in place) should be clear of any dirt, oil, or process material.

7. Loosen the bed knife bolts and adjusting screws, and pull back the bed knife so that the rotor knives will collide as they are installed and rotated.
8. Install new or sharpened knives on each knife seat, making sure that the rotor is still blocked to prevent it from rotating while installing each knife.
9. Before re-installing the knife bolts, wipe them clean with a lightly oil-damped cloth. Do not leave an oil film on the bolt since lubrication can adversely affect the stress on the bolt when torqued to the specified values. It is recommended that the knife bolts be replaced with each new set of knives. This will reduce the risk of bolt failure due to overstretching. Always use the specified replacement bolts.

10. Tighten each set of the knife bolts; making sure that the knife is seated against the back heel in the rotor seat. Before torquing the bolts, check that a 0.001" feeler gage cannot fit between the heel and the back of the knife.
11. Torque the rotor knife bolts to 100 Lbs./ft. (14 Kgm, 135 Nm).
12. Adjust the knife gap with the bed knives and close the machine, following Steps 8-14 in Section 6-4.

6-7 Specifications for Re-sharpening Bed Knives

Every bed knife has two cutting edges, one on each side. When a blade becomes worn, the knives can be rotated. To regrind these knives, refer to the data shown in Figure 14. Replacement of these knives is necessary when their length falls below the recommended tolerance.

The following tables list problems that could occur when using the granulator. This general information may help to locate the cause of the problem and allow it to be resolved promptly. When a problem arises, it is advisable to perform the simplest checks before proceeding to more complicated ones, which may subsequently prove unnecessary.

7-1 General Problems

Problem	Possible Causes	Possible Remedies
Overheating of bearings	Dirt or contamination in the bearing Excessive belt tension No lubrication	Correct source of contamination Adjust belt tension Check bearing seals
Knives moving in their seats	There may be foreign matter on the knives Knife screws loose Knife screws weakened	Carefully clean seat Tighten screws with torque wrench at values specified Screws must not be used more than 6 times
Broken knife	Improper resharpening Extremely hard material Incorrect rotor direction Foreign body in the cutting chamber Faulty fitting of screen	Check knife grinding method used Contact supplier Check rotor direction Look for cause with operator Check assembly procedure
Excessive knife wear	Incorrect knife position Improper knife re-sharpening Abrasive material	Correct the gap or distance between bed knives and rotor knives Check dimensions with Figure 14 and Figure 15. Contact the supplier for special knives
Abnormal screen wear	Incorrect fitting of screen	Check that the screen is correctly seated in its rear position and that it fits perfectly at the front.

Problem	Possible Causes	Possible Remedies
	Abrasive material	Contact the supplier for special knives
Rotor Jamming	<p>Excessive infeed material</p> <p>Total or partial obstruction of the screen holes</p> <p>Insufficient belt tension</p> <p>Knives worn</p> <p>Distance between the knives too small or too large</p> <p>Screen holes too small</p> <p>Failure of air conveying system or discharge system</p>	<p>Reduce amount of material being fed to the machine</p> <p>Remove the screen and clear the holes</p> <p>Check and/or adjust belt tension</p> <p>Replace with new knives</p> <p>Check distance between knives</p> <p>Increase screen hole diameter</p> <p>Check fan rotation and that pipes are not obstructed</p>

7-2 Electrical Problems

Problem	Possible Causes	Possible Remedies
Machine stops for no apparent reason	Safety switch has stopped power	Check that the knobs that operate the safety switch are tightened
Electric motor does not start	No power Overload failure Safety switch not working Cutting chamber too full	Check fuses Check amperage of electric motor Check and replace Empty cutting chamber
Motor starts but does not speed up or take a load	Excessive drive belt tension Motor connected to power source incorrectly Defective starter winding	Check belt tension and adjust Reconnect correctly Check current in each phase. If substantial difference between phases, contact motor manufacturer
Motor starts, but does not gain speed	Bearing excessively worn Cutting chamber full	Replace bearings Empty cutting chamber

Figure 16: Cutting Chamber – Vertical Cross Section

DRAWING CA039060S2

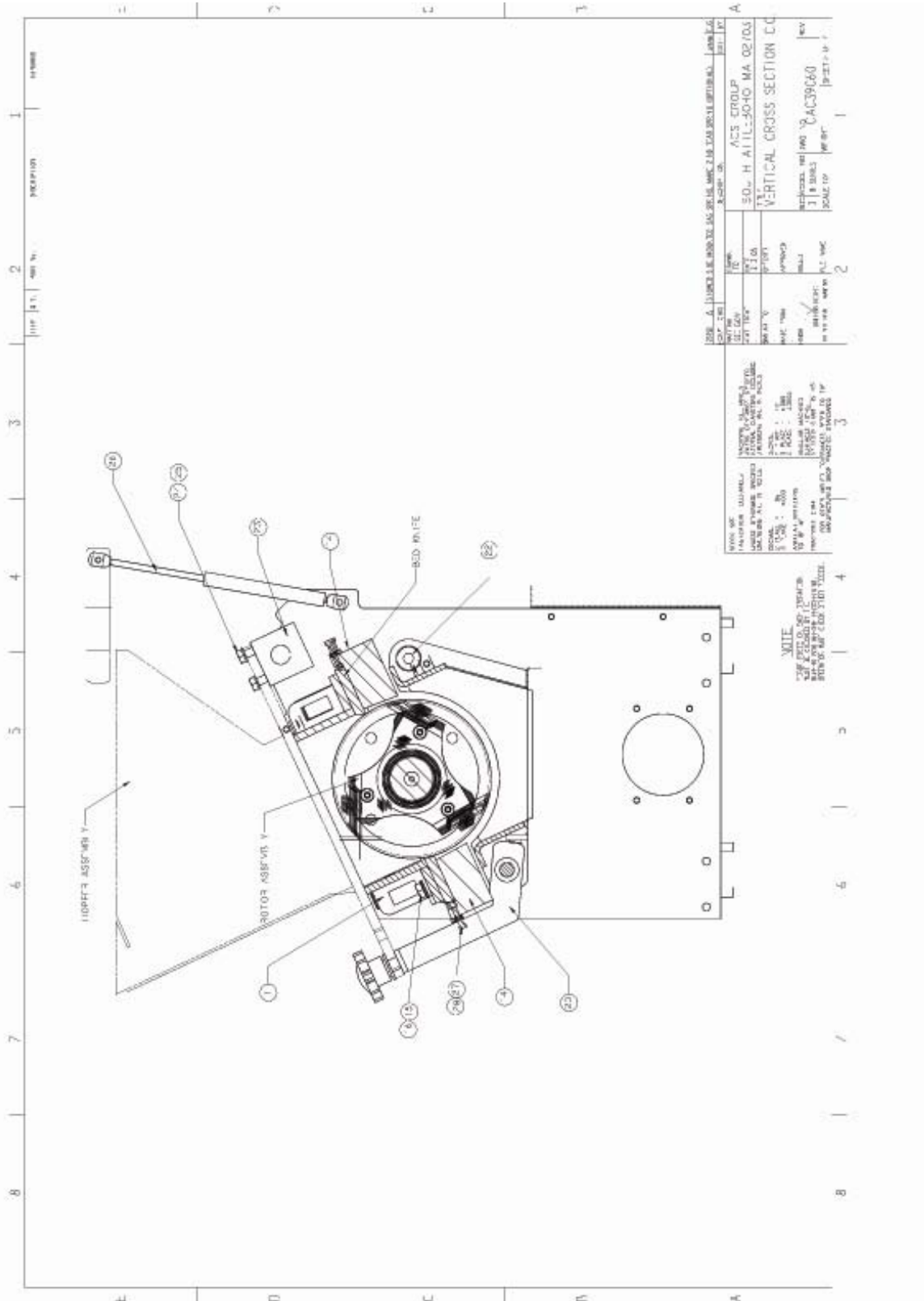

Figure 17: Cutting Chamber – Longitudinal Cross Section
DRAWING CA039060S1

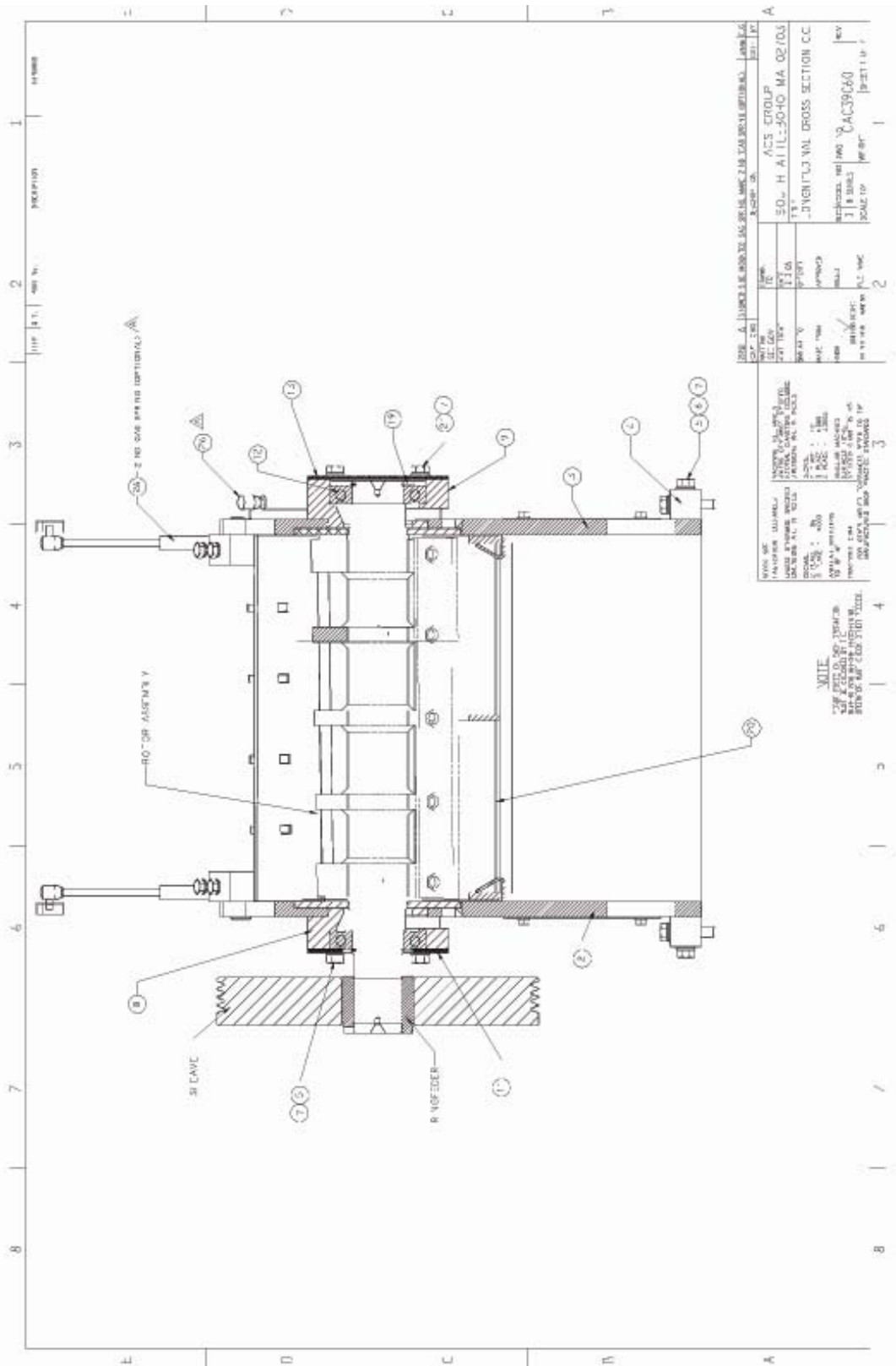
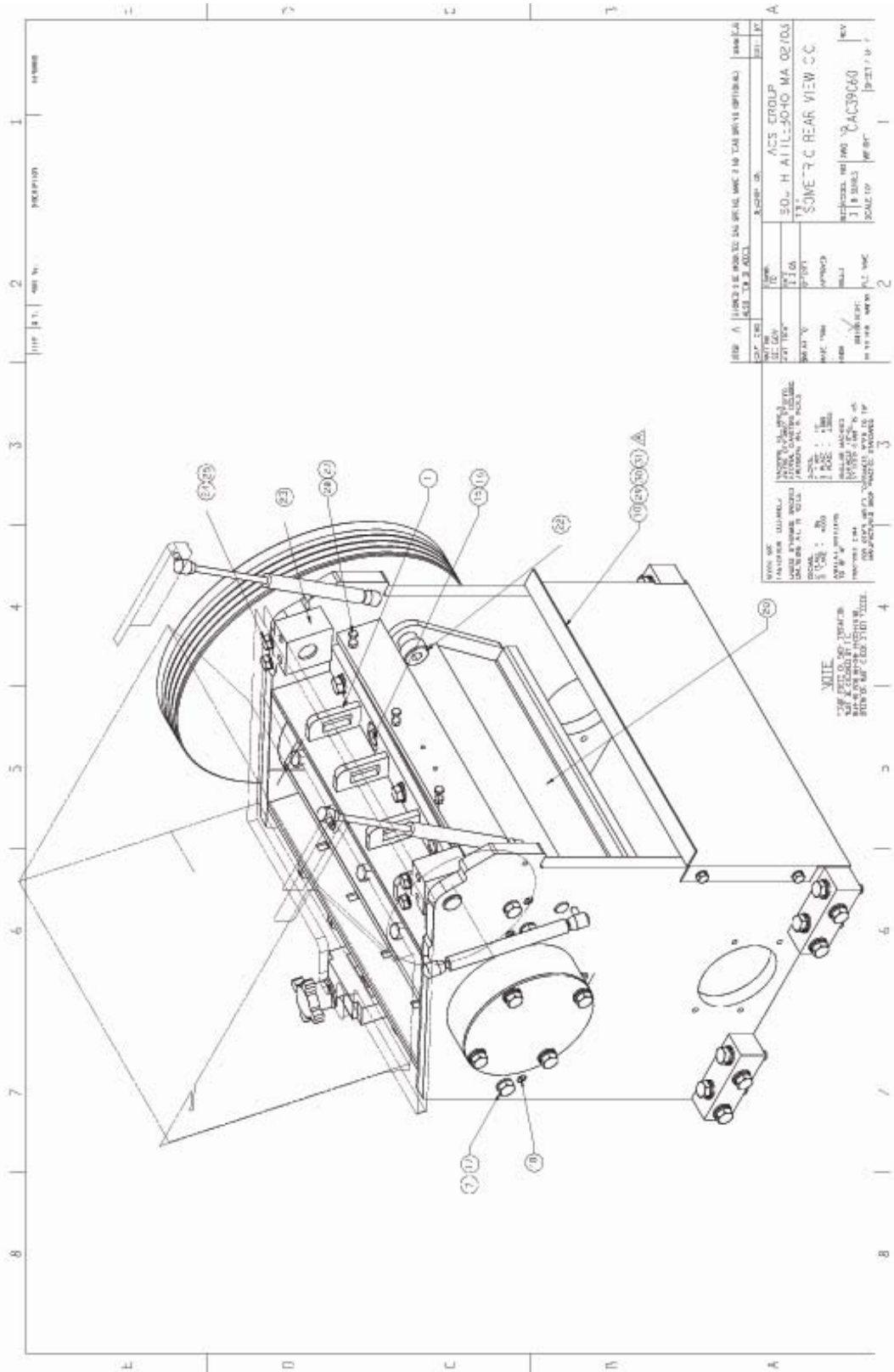

Figure 19: Cutting Chamber – Rear View
DRAWING CA039060S4



9 *Typical Wiring Diagram*



Parts Department

Call *Spare Parts Express* toll-free 8am – 8PM EST (800) 229-2919. Cumberland Engineering OEM quality replacement and spare parts ensure operation at design specifications. Please have the model and serial number of your equipment when you call. Consult the Customer Parts List included in your information packet for replacement part numbers.



Service Department

Call toll free (800) 229-2919 8am – 8pm EST- *Emergency service available 24 hours a day.* Cumberland Engineering has a qualified service department ready to help. Service contracts are available for most Cumberland Engineering products.



Sales Department

Call (508)399-6400 Monday – Friday, 8am – 5pm EST
Cumberland Engineering sells products via a worldwide network of independent sales representatives. Contact our Sales Department for the name of the sales representative nearest you.



Cumberland Engineering
100 Roddy Avenue
South Attleboro, MA 02703
Tel: (508) 399-6400

Fax: (508) 399-6653

Service Notes

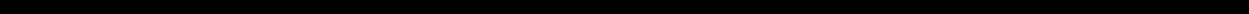

A series of 20 thin, horizontal black lines spaced evenly down the page, providing a template for writing service notes.

Warranty

Cumberland Engineering, Corp. warrants all equipment manufactured by it to be free from defects in workmanship and material when used under recommended conditions. The Company's obligation is limited to repair or replace FOB the factory any parts that are returned prepaid within one year of equipment shipment to the original purchaser, and which, in the Company's opinion, are defective. Any replacement part assumes the unused portion of this warranty.

This parts warranty does not cover any labor charges for replacement of parts, adjustment repairs, or any other work. This warranty does not apply to any equipment which, in the Company's opinion, has been subjected to misuse, negligence, or operation in excess of recommended limits or which has been repaired or altered without the Company's express authorization. If the serial number has been defaced or removed from the component, the warranty on that component is void. Defective parts become the property of the warrantor and are to be returned.

The Company is not liable for any incidental, consequential, or special damages or expenses. The Company's obligation for parts not furnished as components of its manufactured equipment is limited to the warranty of the manufacturers of said parts.

Any sales, use, excise, or other tax incident to the replacement of parts under this warranty is the responsibility of the purchaser.

The company neither assumes nor authorizes any other persons to assume for it any liability in connection with the sale of its equipment not expressed in this warranty.

Many types of Cumberland Engineering, Corp. equipment carry an additional one-year service policy. Consult your Cumberland Engineering, Corp. sales representative for specific details.



100 Roddy Avenue • South Attleboro, MA 02703-7951
Phone (508) 399-6400 • Fax (508) 399-6653
<http://www.cumberland-plastics.com>



Auxiliary Equipment for the Process Industries
100 Roddy Avenue • South Attleboro, MA 02703-7951
(508) 399-6400 • Fax (508) 399-6653